



HERITAGE ▪ VISION ▪ OPPORTUNITY

CONTRACT DOCUMENTS FOR

PAVEMENT MANAGEMENT PROGRAM 2026 (CONCRETE) CIP PROJECT NO. 336-31705

**Bid Opening
Wednesday, February 18, 2026 at 2:00 p.m.**

**Location of Bid Submittal:
City Clerk
City Hall
150 City Park Way
Brentwood, CA 94513**



**Approved by:
Allen Baquilar
Director of Engineering/City Engineer**

Signature

January 22, 2026

Date

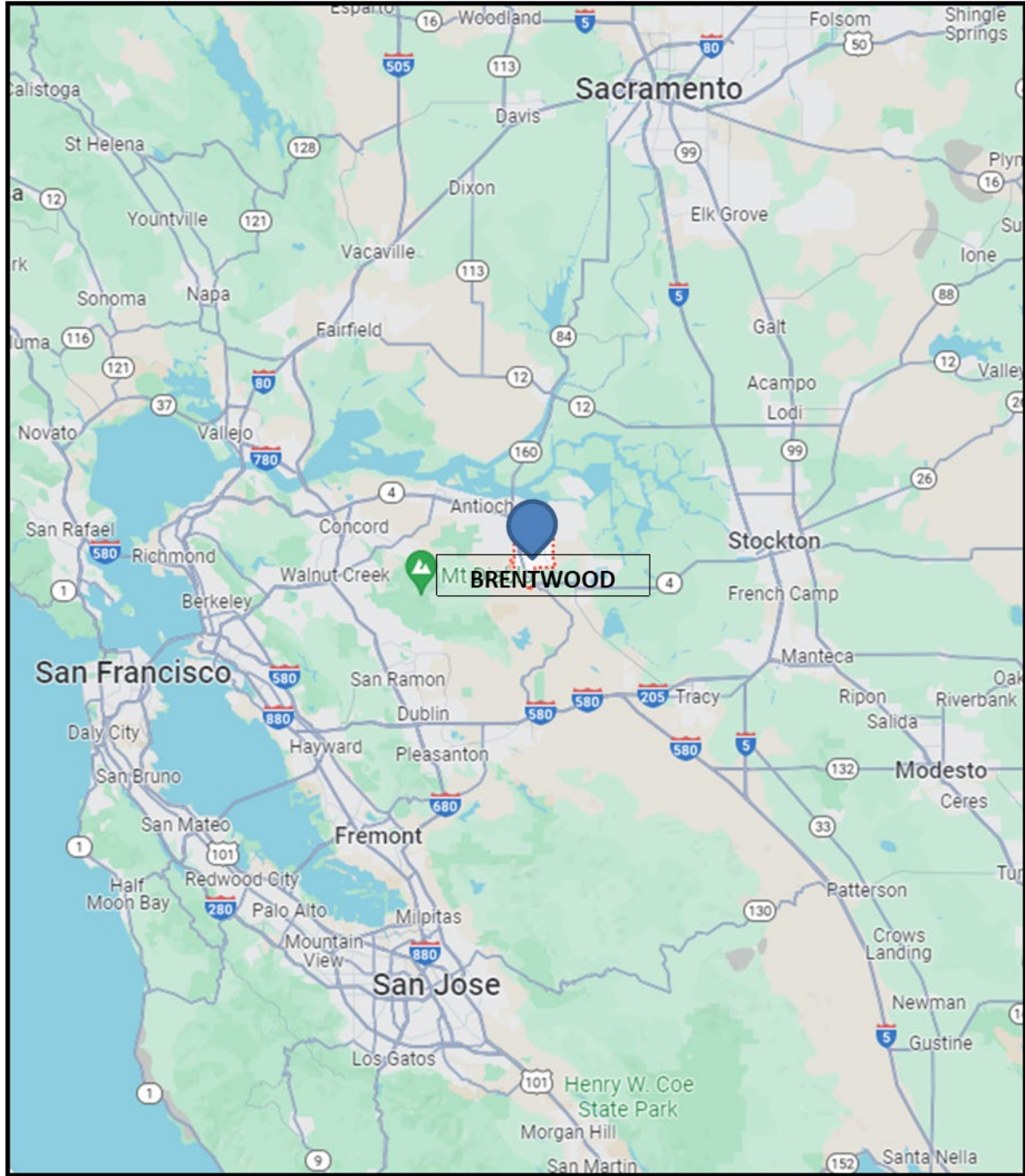

LOCATION MAP
City of Brentwood

TABLE OF CONTENTS

Notice Inviting Bids	1
Instructions to Bidders	2
Bid Proposal.....	8
Bid Schedule	11
Subcontractor List.....	12
Noncollusion Declaration	13
Bid Bond.....	14
Bidder’s Questionnaire	16
Contract	19
Payment Bond.....	23
Performance Bond	25
General Conditions	27
Article 1 - Definitions.....	27
Definitions.....	27
Article 2 - Roles and Responsibilities	29
2.1 City	29
2.2 Contractor.....	30
2.3 Subcontractors	32
2.4 Coordination of Work.....	33
2.5 Submittals.....	34
2.6 Shop Drawings	34
Article 3 - Contract Documents.....	35
3.1 Interpretation of Contract Documents	35
3.2 Order of Precedence	36
3.3 Caltrans Standard Specifications	36
3.4 Informational Documents	37
3.5 Current Versions	37
3.6 Conformed Copies	37
Article 4 - Bonds, Indemnity, and Insurance	38
4.1 Payment and Performance Bonds	38
4.2 Indemnity	38
4.3 Insurance.....	38
Article 5 - Contract Time	40
5.1 Time is of the Essence	40
5.2 Schedule Requirements.....	41
5.3 Delay and Extensions of Contract Time.....	43
5.4 Liquidated Damages	46
Article 6 - Contract Modification	46
6.1 Contract Modification.....	46
6.2 Contractor Change Order Requests	48
6.3 Adjustments to Contract Price.....	48
6.4 Unilateral Change Order	49
6.5 Non-Compliance Deemed Waiver.....	49
Article 7 - General Construction Provisions	49
7.1 Permits, Fees, Business License, and Taxes	49
7.2 Temporary Facilities	50
7.3 Noninterference and Site Management	50
7.4 Signs.....	50
7.5 Project Site and Nearby Property Protections.	51
7.6 Materials and Equipment.....	52
7.7 Substitutions	52
7.8 Testing and Inspection	53

7.9	Project Site Conditions and Maintenance	54
7.10	Instructions and Manuals	56
7.11	As-built Drawings	56
7.12	Existing Utilities	56
7.13	Notice of Excavation.....	57
7.14	Trenching and Excavations of Four Feet or More.....	57
7.15	Trenching of Five Feet or More	57
7.16	New Utility Connections	58
7.17	Lines and Grades.....	58
7.18	Historic or Archeological Items.....	58
7.19	Environmental Control.....	58
7.20	Noise Control.....	59
7.21	Mined Materials.....	59
Article 8 - Payment		59
8.1	Schedule of Values	59
8.2	Progress Payments	59
8.3	Adjustment of Payment Application	59
8.4	Early Occupancy.....	60
8.5	Retention	60
8.6	Payment to Subcontractors and Suppliers.....	61
8.7	Final Payment	62
8.8	Release of Claims	62
8.9	Warranty of Title	62
Article 9 - Labor Provisions		62
9.1	Discrimination Prohibited.....	62
9.2	Labor Code Requirements	62
9.3	Prevailing Wages	63
9.4	Payroll Records	63
9.5	Labor Compliance	63
Article 10 - Safety Provisions		64
10.1	Safety Precautions and Programs	64
10.2	Hazardous Materials	64
10.3	Material Safety	64
10.4	Hazardous Condition.....	65
10.5	Emergencies	65
Article 11 - Completion and Warranty Provisions		65
11.1	Final Completion	65
11.2	Warranty.....	66
11.3	Use Prior to Final Completion	67
11.4	Substantial Completion	67
Article 12 - Dispute Resolution		67
12.1	Claims.....	67
12.2	Claims Submission.....	68
12.3	City's Response	69
12.4	Meet and Confer.....	70
12.5	Mediation and Government Code Claims	70
12.6	Tort Claims	71
12.7	Arbitration	71
12.8	Burden of Proof and Limitations.....	71
12.9	Legal Proceedings.....	71
12.10	Other Disputes	71
Article 13 - Suspension and Termination.....		72
13.1	Suspension for Cause	72
13.2	Suspension for Convenience	72
13.3	Termination for Default.....	72
13.4	Termination for Convenience	74

13.5	Actions Upon Termination for Default or Convenience	74
Article 14 - Miscellaneous Provisions	75
14.1	Assignment of Unfair Business Practice Claims	75
14.2	Provisions Deemed Inserted	75
14.3	Waiver	75
14.4	Titles, Headings, and Groupings	76
14.5	Statutory and Regulatory References	76
14.6	Survival.....	76
Special Conditions	77
Technical Specifications	79

Notice Inviting Bids

- 1. Bid Submission.** The City of Brentwood (“City”) will accept sealed bids for its Pavement Management Program 2026 (Concrete), CIP Project No. 336-31705 Project (“Project”), by or before Wednesday, February 18, 2026 at 2:00 p.m., at its City Clerk’s office, located at City Hall, third floor, 150 City Park Way, Brentwood, California 94513. Shortly thereafter, the bids will be publicly opened and read aloud at City Hall, Council Chamber, 150 City Park Way, Brentwood, California 94513.

Bids that are hand delivered must be handed directly to the City employee staffing the City Hall third floor window. If the window is not staffed, you must contact the City Clerk by dialing 5440, using the phone at the third floor window, and hand deliver it to the City employee answering the door.

- 2. Project Information.**

- 2.1 Location and Description.** The Project is located at citywide locations and is described as follows: removing and replacing concrete sidewalk, American with Disabilities Act (ADA) ramps, driveway approach, curb and gutter; adjusting utilities to grade; and all other work necessary to construct the project complete and in satisfactory condition, all as shown on the Contract Documents and/or as specified herein.

- 2.2 Final Completion.** The Project must be fully completed within 70 calendar days from the start date set forth in the Notice to Proceed. City anticipates that the Work will begin on or about May 4, 2026, but the anticipated start date is provided solely for convenience and is neither certain nor binding.

- 2.3 Estimated Cost.** The estimated construction cost is \$471,510.

- 3. License and Registration Requirements.**

- 3.1 License.** This Project requires a valid California contractor’s license for the following classification(s): Class A.

- 3.2 DIR Registration.** City may not accept a Bid Proposal from or enter into the Contract with a bidder, without proof that the bidder is registered with the California Department of Industrial Relations (“DIR”) to perform public work pursuant to Labor Code § 1725.5, subject to limited legal exceptions.

- 4. Contract Documents.** The plans, specifications, bid forms and contract documents for the Project, and any addenda thereto (“Contract Documents”) may be downloaded from the City’s website located at: <http://www.brentwoodca.gov/projects-bids-rfps>.

- 5. Bid Security.** The Bid Proposal must be accompanied by bid security of ten percent of the maximum bid amount, in the form of a cashier’s or certified check made payable to City, or a bid bond executed by a surety licensed to do business in the State of California on the Bid Bond form included with the Contract Documents. The bid security must guarantee that within ten days after City issues the Notice of Potential Award, the successful bidder will execute the Contract and submit the payment and performance bonds, insurance certificates and endorsements, valid Certificates of Reported Compliance as required under the California Air Resources Board’s In-Use Off-Road Diesel-Fueled Fleets Regulation (13 CCR § 2449 et seq.) (“Off-Road Regulation”), if applicable, and any other submittals required by the Contract Documents, including information regarding local purchases and local labor if required by the Instructions to Bidders, using the form provided with the Notice of Potential Award, and as specified in the Notice of Potential Award.

6. Prevailing Wage Requirements.

6.1 General. Pursuant to California Labor Code § 1720 et seq., this Project is subject to the prevailing wage requirements applicable to the locality in which the Work is to be performed for each craft, classification or type of worker needed to perform the Work, including employer payments for health and welfare, pension, vacation, apprenticeship and similar purposes.

6.2 Rates. The prevailing rates are on file with the City and are available online at <http://www.dir.ca.gov/DLSR>. Each Contractor and Subcontractor must pay no less than the specified rates to all workers employed to work on the Project. The schedule of per diem wages is based upon a working day of eight hours. The rate for holiday and overtime work must be at least time and one-half.

6.3 Compliance. The Contract will be subject to compliance monitoring and enforcement by the DIR, under Labor Code § 1771.4.

7. Performance and Payment Bonds. The successful bidder will be required to provide performance and payment bonds, each for 100% of the Contract Price, as further specified in the Contract Documents.

8. Substitution of Securities. Substitution of appropriate securities in lieu of retention amounts from progress payments is permitted under Public Contract Code § 22300.

9. Subcontractor List. Each Subcontractor must be registered with the DIR to perform work on public projects. Each bidder must submit a completed Subcontractor List form with its Bid Proposal, including the name, location of the place of business, California contractor license number, DIR registration number, and percentage of the Work to be performed (based on the base bid price) for each Subcontractor that will perform Work or service or fabricate or install Work for the prime contractor in excess of one-half of 1% of the bid price, using the Subcontractor List form included with the Contract Documents.

10. Instructions to Bidders. All bidders should carefully review the Instructions to Bidders for more detailed information before submitting a Bid Proposal. The definitions provided in Article 1 of the General Conditions apply to all of the Contract Documents, as defined therein, including this Notice Inviting Bids.

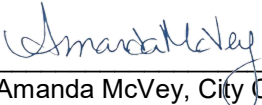
By:  Date: January 22, 2026
Amanda McVey, City Clerk

Publication Date: January 30, 2026

END OF NOTICE INVITING BIDS

Instructions to Bidders

Each Bid Proposal submitted to the City of Brentwood ("City") for its **Pavement Management Program 2026 (Concrete), CIP Project No. 336-31705 Project ("Project")** must be submitted in accordance with the following instructions and requirements:

1. Bid Submission.

- 1.1 General.** Each Bid Proposal must be completed, using the form provided in the Contract Documents, signed, and submitted to City in a sealed envelope, with all required forms and attachments, by or before the date and time set forth in Section 1 of the Notice Inviting Bids, or as amended by subsequent addendum. Faxed or emailed Bid Proposals will not be accepted, unless otherwise specified. Late submissions will be returned unopened. City reserves the right to postpone the date or time for receiving or opening bids. Each bidder is solely responsible for all of its costs to prepare and submit its bid and by submitting a bid waives any right to recover those costs from City. The bid price(s) must include all costs to perform the Work as specified, including all labor, material, supplies, and equipment and all other direct or indirect costs such as applicable taxes, insurance and overhead.
- 1.2 Bid Envelope.** The sealed envelope containing the Bid Proposal and all required forms and attachments must be clearly labeled and addressed as follows:

BID PROPOSAL:

Pavement Management Program 2026 (Concrete)
CIP Project No. 336-31705

City Clerk
Attn: Amanda McVey
City of Brentwood
150 City Park Way
Brentwood, CA 94513

The envelope must also be clearly labeled, as follows, with the bidder's name, address, and its registration number with the California Department of Industrial Relations ("DIR") for bidding on public works contracts (Labor Code §§ 1725.5 and 1771.1):

[Contractor company name]
[street address]
[city, state, zip code]
DIR Registration No: _____

- 1.3 DIR Registration.** Subject to limited legal exceptions for joint venture bids and federally-funded projects, City may not accept a Bid Proposal from a bidder without proof that the bidder is registered with the DIR to perform public work under Labor Code § 1725.5. If City is unable to confirm that the bidder is currently registered with the DIR, City may disqualify the bidder and return its bid unopened. (Labor Code §§ 1725.5 and 1771.1(a).)
- 2. Bid Proposal Form and Enclosures.** Each Bid Proposal must be completed in ink using the Bid Proposal form included with the Contract Documents. The Bid Proposal form must be fully completed without interlineations, alterations, or erasures. Any necessary corrections must be clear and legible, and must be initialed by the bidder's authorized

representative. A Bid Proposal submitted with exceptions or terms such as “negotiable,” “will negotiate,” or similar, will be considered nonresponsive. Each Bid Proposal must be accompanied by bid security, as set forth in Section 4 below, and by a completed Subcontractor List and Non-Collusion Declaration using the forms included with the Contract Documents, and any other required enclosures, as applicable.

- 3. Authorization and Execution.** Each Bid Proposal must be signed by the bidder’s authorized representative. A Bid Proposal submitted by a partnership must be signed in the partnership name by a general partner with authority to bind the partnership. A Bid Proposal submitted by a corporation must be signed with the legal name of the corporation, followed by the signature and title of two officers of the corporation with full authority to bind the corporation to the terms of the Bid Proposal, under California Corporations Code § 313.
- 4. Bid Security.** Each Bid Proposal must be accompanied by bid security of ten percent of the maximum bid amount, in the form of a cashier’s check or certified check, made payable to the City, or bid bond using the form included in the Contract Documents and executed by a surety licensed to do business in the State of California. The bid security must guarantee that, within ten days after issuance of the Notice of Potential Award, the bidder will: execute and submit the enclosed Contract for the bid price; submit payment and performance bonds for 100% of the maximum Contract Price; submit the insurance certificates and endorsements; and submit valid Certificates of Reported Compliance as required by the Off-Road Regulation, if applicable, and any other submittals, if any, required by the Contract Documents, including information regarding local purchases and local labor if required by these Instructions to Bidders, using the form provided with the Notice of Potential Award, and as specified in the Notice of Potential Award. A Bid Proposal may not be withdrawn for a period of 60 days after the bid opening without forfeiture of the bid security, except as authorized for material error under Public Contract Code § 5100 et seq.
- 5. Requests for Information.** Questions or requests for clarifications regarding the Project, the bid procedures, or any of the Contract Documents must be submitted in writing to engineering@brentwoodca.gov. Oral responses are not authorized and are not binding on the City. Bidders should submit any such written inquiries no later than 4:00 p.m. at least five Working Days before the scheduled bid opening. Questions received any later might not be addressed before the bid deadline. An interpretation or clarification by City in response to a written inquiry will be issued in an addendum.
- 6. Pre-Bid Investigation.**

 - 6.1 General.** Each bidder is solely responsible at its sole expense for diligent and thorough review of the Contract Documents, examination of the Project site, and reasonable and prudent inquiry concerning known and potential site and area conditions prior to submitting a Bid Proposal. Each bidder is responsible for knowledge of conditions and requirements which reasonable review and investigation would have disclosed. However, except for any areas that are open to the public at large, bidders may not enter property owned or leased by the City or the Project site without prior written authorization from City.
 - 6.2 Document Review.** Each bidder is responsible for review of the Contract Documents and any Informational Documents provided e.g., as-builts, technical reports, test data, and the like. A bidder is responsible for notifying City of any errors, omissions, inconsistencies, or conflicts it discovers in the Contract Documents, acting solely in its capacity as a contractor and subject to the limitations of Public Contract Code § 1104. Notification of any such errors, omissions, inconsistencies, or conflicts must be submitted in writing to the City no later than five Working Days before the scheduled bid opening. (See Section 5,

above.) City expressly disclaims responsibility for assumptions a bidder might draw from the presence or absence of information provided by City.

- 6.3 Project Site.** Questions regarding the availability of soil test data, water table elevations, and the like should be submitted to the City in writing, as specified in Section 5, above. Any subsurface exploration at the Project site must be done at the bidder's expense, but only with prior written authorization from City. All soil data and analyses available for inspection or provided in the Contract Documents apply only to the test hole locations. Any water table elevation indicated by a soil test report existed on the date the test hole was drilled. The bidder is responsible for determining and allowing for any differing soil or water table conditions during construction. Because groundwater levels may fluctuate, difference(s) in elevation between ground water shown in soil boring logs and ground water actually encountered during construction will not be considered changed Project site conditions. Actual locations and depths must be determined by bidder's field investigation. The bidder may request access to underlying or background information on the Project site in City's possession that is necessary for the bidder to form its own conclusions, including, if available, record drawings or other documents indicating the location of subsurface lines, utilities, or other structures.
- 6.4 Utility Company Standards.** The Project must be completed in a manner that satisfies the standards and requirements of any affected utility companies or agencies (collectively, "utility owners"). The successful bidder may be required by the third party utility owners to provide detailed plans prepared by a California registered civil engineer showing the necessary temporary support of the utilities during coordinated construction work. Bidders are directed to contact the affected third party utility owners about their requirements before submitting a Bid Proposal.
- 7. Bidders Interested in More Than One Bid.** No person, firm, or corporation may submit or be a party to more than one Bid Proposal unless alternate bids are specifically called for. However, a person, firm, or corporation that has submitted a subcontract proposal or quote to a bidder may submit subcontract proposals or quotes to other bidders.
- 8. Addenda.** Subject to the limitations of Public Contract Code § 4104.5, City reserves the right to issue addenda prior to bid time. Any addenda issued prior to the bid opening are part of the Contract Documents. Each bidder is solely responsible for ensuring it has received and reviewed all addenda prior to submitting its bid. Bidders should check City's website periodically for any addenda or updates on the Project at: <http://www.brentwoodca.gov/projects-bids-rfps>.
- 9. Brand Designations and "Or Equal" Substitutions.** Any specification designating a material, product, thing, or service by specific brand or trade name, followed by the words "or equal," is intended only to indicate quality and type of item desired, and bidders may request use of any equal material, product, thing, or service. All data substantiating the proposed substitute as an equal item must be submitted with the written request for substitution. A request for substitution must be submitted within 35 days after Notice of Potential Award unless otherwise provided in the Contract Documents. This provision does not apply to materials, products, things, or services that may lawfully be designated by a specific brand or trade name under Public Contract Code § 3400(c).
- 10. Bid Protest.** Any bid protest against another bidder must be submitted in writing and received by the City Clerk at 150 City Park Way, Brentwood, CA 94513 or sent via email at CityClerk@brentwoodca.gov before 5:00 p.m. no later than two Working Days following bid opening ("Bid Protest Deadline") and must comply with the following requirements:

- 10.1 General.** Only a bidder who has actually submitted a Bid Proposal is eligible to submit a bid protest against another bidder. Subcontractors are not eligible to submit bid protests. A bidder may not rely on the bid protest submitted by another bidder, but must timely pursue its own protest. For purposes of this Section 10, a “Working Day” means a day that City is open for normal business, and excludes weekends and holidays observed by City. Pursuant to Public Contract Code § 4104, inadvertent omission of a Subcontractor’s DIR registration number on the Subcontractor List form is not grounds for a bid protest, provided it is corrected within 24 hours of the bid opening or as otherwise provided under Labor Code § 1771.1(b).
- 10.2 Protest Contents.** The bid protest must contain a complete statement of the basis for the protest and must include all supporting documentation. Material submitted after the Bid Protest Deadline will not be considered. The protest must refer to the *specific* portion or portions of the Contract Documents upon which the protest is based. The protest must include the name, address, email address, and telephone number of the protesting bidder and any person submitting the protest on behalf of or as an authorized representative of the protesting bidder.
- 10.3 Copy to Protested Bidder.** Upon submission of its bid protest to City, the protesting bidder must also concurrently transmit the protest and all supporting documents to the protested bidder, and to any other bidder who has a reasonable prospect of receiving an award depending upon the outcome of the protest, by email or hand delivery to ensure delivery before the Bid Protest Deadline.
- 10.4 Response to Protest.** The protested bidder may submit a written response to the protest, provided the response is received by City before 5:00 p.m., within two Working Days after the Bid Protest Deadline or after actual receipt of the bid protest, whichever is sooner (the “Response Deadline”). The response must attach all supporting documentation. Material submitted after the Response Deadline will not be considered. The response must include the name, address, email address, and telephone number of the person responding on behalf of or representing the protested bidder if different from the protested bidder.
- 10.5 Copy to Protesting Bidder.** Upon submission of its response to the bid protest to the City, the protested bidder must also concurrently transmit by email or hand delivery, by or before the Response Deadline, a copy of its response and all supporting documents to the protesting bidder and to any other bidder who has a reasonable prospect of receiving an award depending upon the outcome of the protest.
- 10.6 Exclusive Remedy.** The procedure and time limits set forth in this Section are mandatory and are the bidder’s sole and exclusive remedy in the event of a bid protest. A bidder’s failure to comply with these procedures will constitute a waiver of any right to further pursue a bid protest, including filing a Government Code Claim or initiation of legal proceedings.
- 10.7 Right to Award.** City reserves the right, acting in its sole discretion, to reject any bid protest that it determines lacks merit, to award the Contract to the bidder it has determined to be the responsible bidder submitting the lowest responsive bid, and to issue a Notice to Proceed with the Work notwithstanding any pending or continuing challenge to its determination.
- 11. Reservation of Rights.** City reserves the unfettered right, acting in its sole discretion, to waive or to decline to waive any immaterial bid irregularities; to accept or reject any or all

bids; to cancel or reschedule the bid; to postpone or abandon the Project entirely; or to perform all or part of the Work with its own forces. The Contract will be awarded, if at all, within 60 days after opening of bids or as otherwise specified in the Special Conditions, to the responsible bidder that submitted the lowest responsive bid. Any planned start date for the Project represents the City's expectations at the time the Notice Inviting Bids was first issued. City is not bound to issue a Notice to Proceed by or before such planned start date, and it reserves the right to issue the Notice to Proceed when the City determines, in its sole discretion, the appropriate time for commencing the Work. The City expressly disclaims responsibility for any assumptions a bidder might draw from the presence or absence of information provided by the City in any form. Each bidder is solely responsible for its costs to prepare and submit a bid, including site investigation costs.

- 12. Bonds.** Within ten calendar days following City's issuance of the Notice of Potential Award to the successful bidder, the bidder must submit payment and performance bonds to City as specified in the Contract Documents using the bond forms included in the Contract Documents. All required bonds must be calculated on the maximum total Contract Price as awarded, including additive alternates, if applicable.
- 13. License(s).** The successful bidder and its Subcontractor(s) must possess the California contractor's license(s) in the classification(s) required by law to perform the Work. The successful bidder must also obtain a City business license within 10 days following City's issuance of the Notice of Potential Award. Subcontractors must also obtain a City business license before performing any Work.
- 14. Ineligible Subcontractor.** Any Subcontractor who is ineligible to perform work on a public works project under Labor Code §§ 1777.1 or 1777.7 is prohibited from performing work on the Project.
- 15. Safety Orders.** If the Project includes construction of a pipeline, sewer, sewage disposal system, boring and jacking pits, or similar trenches or open excavations, which are five feet or deeper, each bid must include a bid item for adequate sheeting, shoring, and bracing, or equivalent method, for the protection of life or limb, which comply with safety orders as required by Labor Code § 6707.
- 16. In-Use Off-Road Diesel-Fueled Fleets.** If the Project involves the use of vehicles subject to the California Air Resources Board's In-Use Off-Road Diesel-Fueled Fleets Regulation (13 CCR § 2449 et seq.) ("Off-Road Regulation"), then within ten calendar days following City's issuance of the Notice of Potential Award to the successful bidder, the bidder must submit to City valid Certificates of Reported Compliance for its fleet and its listed Subcontractors, if applicable, in accordance with the Off-Road Regulation, unless exempt under the Off-Road Regulation.
- 17. Subcontractor Work Limits.** The prime contractor must perform at least 50% of the Work on the Project, calculated as a percentage of the base bid price, with its own forces, except for any Work identified as "Specialty Work" in the Contract Documents. The total bid amount for any such Specialty Work, as shown on the Bid Schedule, may be deducted from the base bid price before computing the 50% self-performance requirement. The remaining Work may be performed by qualified Subcontractor(s).
- 18. Bid Schedule.** Each bidder must complete the Bid Schedule form with unit prices as indicated, and submit the completed Bid Schedule with its Bid Proposal.
 - 18.1 Incorrect Totals.** In the event a computational error for any bid item (base bid or alternate) results in an incorrect extended total for that item, the submitted base bid or bid alternate total will be adjusted to reflect the corrected amount as the product

of the estimated quantity and the unit cost. In the event of a discrepancy between the actual total of the itemized or unit prices shown on the Bid Schedule for the base bid, and the amount entered as the base bid on the Bid Proposal form, the actual total of the itemized or unit prices shown on the Bid Schedule for the base bid will be deemed the base bid price. Likewise, in the event of a discrepancy between the actual total of the itemized or unit prices shown on the Bid Schedule for any bid alternate, and the amount entered for the alternate on the Bid Proposal form, the actual total of the itemized prices shown on the Bid Schedule for that alternate will be deemed the alternate price. Nothing in this provision is intended to prevent a bidder from requesting to withdraw its bid for material error under Public Contract Code § 5100 et seq.

- 18.2 Estimated Quantities.** Unless identified as a “Final Pay Quantity,” the quantities shown on the Bid Schedule are estimated and the actual quantities required to perform the Work may be greater or less than the estimated amount. The Contract Price will be adjusted to reflect the actual quantities required for the Work based on the itemized or unit prices provided in the Bid Schedule, with no allowance for anticipated profit for quantities that are deleted or decreased, and no increase in the unit price, and without regard to the percentage increase or decrease of the estimated quantity and the actual quantity.

END OF INSTRUCTIONS TO BIDDERS

Bid Proposal

**Pavement Management Program 2026 (Concrete)
CIP Project No. 336-31705**

_____ (“Bidder”) hereby submits this Bid Proposal to the City of Brentwood (“City”) for the above-referenced project (“Project”) in response to the Notice Inviting Bids and in accordance with the Contract Documents referenced in the Notice.

1. **Base Bid.** Bidder proposes to perform and fully complete the Work for the Project as specified in the Contract Documents, within the time required for full completion of the Work, including all labor, materials, supplies, and equipment and all other direct or indirect costs including, but not limited to, taxes, insurance and all overhead, for the following price (“Base Bid”):
\$ _____.

2. **Addenda.** Bidder agrees that it has confirmed receipt of or access to, and reviewed, all addenda issued for this bid. Bidder waives any claims it might have against the City based on its failure to receive, access, or review any addenda for any reason. Bidder specifically acknowledges receipt of the following addenda:

Addendum:	Date Received:	Addendum:	Date Received:
#01	_____	#05	_____
#02	_____	#06	_____
#03	_____	#07	_____
#04	_____	#08	_____

3. **Bidder’s Certifications and Warranties.** By signing and submitting this Bid Proposal, Bidder certifies and warrants the following:

- 3.1 **Examination of Contract Documents.** Bidder has thoroughly examined the Contract Documents and represents that, to the best of Bidder’s knowledge, there are no errors, omissions, or discrepancies in the Contract Documents, subject to the limitations of Public Contract Code § 1104.
- 3.2 **Examination of Worksite.** Bidder has had the opportunity to examine the Worksite and local conditions at the Project location.
- 3.3 **Bidder Responsibility.** Bidder is a responsible bidder, with the necessary ability, capacity, experience, skill, qualifications, workforce, equipment, and resources to perform or cause the Work to be performed in accordance with the Contract Documents and within the Contract Time.
- 3.4 **Responsibility for Bid.** Bidder has carefully reviewed this Bid Proposal and is solely responsible for any errors or omissions contained in its completed bid. All statements and information provided in this Bid Proposal and enclosures are true and correct to the best of Bidder’s knowledge.
- 3.5 **Nondiscrimination.** In preparing this bid, the Bidder has not engaged in discrimination against any prospective or present employee or Subcontractor on grounds of race, color, ancestry, national origin, ethnicity, religion, sex, sexual orientation, age, disability, or marital status.
- 3.6 **Iran Contracting Act.** If the Contract Price exceeds \$1,000,000, Bidder is not identified on a list created under the Iran Contracting Act, Public Contract Code § 2200 et seq. (the “Act”),

as a person engaging in investment activities in Iran, as defined in the Act, or is otherwise expressly exempt under the Act.

4. **Award of Contract.** By signing and submitting this Bid Proposal, Bidder agrees that, if City issues the Notice of Potential Award to Bidder, then within ten days following issuance of the Notice of Potential Award to Bidder, Bidder will do all of the following:
- 4.1 **Execute Contract.** Enter into the Contract with City in accordance with the terms of this Bid Proposal, by signing and submitting to City the Contract prepared by City using the form included with the Contract Documents;
 - 4.2 **Submit Required Bonds.** Submit to City a payment bond and a performance bond, each for 100% of the Contract Price, using the bond forms provided and in accordance with the requirements of the Contract Documents;
 - 4.3 **Insurance Requirements.** Submit to City the insurance certificate(s) and endorsement(s) as required by the Contract Documents; and
 - 4.4 **Certificates of Reported Compliance.** Submit to City valid Certificates of Reported Compliance for its fleet and its listed Subcontractors, if applicable, if the Project involves the use of vehicles subject to the Off-Road Regulation. (See Section 16 of the Instructions to Bidders.)
 - 4.5 **Local Purchase and Labor Information (If Required).** Submit to City information regarding expected local purchases and local labor for the Project, if required by the Instructions to Bidders, using the form provided with the Notice of Potential Award.
5. **Bid Security.** As a guarantee that, if awarded the Contract, Bidder will perform its obligations under Section 4 above, Bidder is enclosing bid security in the amount of ten percent of its maximum bid amount in one of the following forms (check one):

_____ A cashier's check or certified check payable to City and issued by
_____ [Bank name] in the amount of
\$ _____.

_____ A bid bond, using the Bid Bond form included with the Contract Documents, payable to City and executed by a surety licensed to do business in the State of California.

[Signatures are on the following page]

This Bid Proposal is hereby submitted on _____, 20__.

s/ _____

Name and Title

s/ _____
[See Section 3 of Instructions to Bidders]

Name and Title

Company Name

License #, Expiration Date, and Classification

Address

DIR Registration #

City, State, Zip

Phone

Contact Name

Contact Email

END OF BID PROPOSAL

Bid Schedule

This Bid Schedule must be completed in ink and included with the sealed Bid Proposal. Pricing must be provided for each Bid Item as indicated. Items marked "(SW)" are Specialty Work that must be performed by a qualified Subcontractor. The lump sum or unit cost for each item must be inclusive of all costs, whether direct or indirect, including profit and overhead. The sum of all amounts entered in the "Extended Total Amount" column must be identical to the Base Bid price entered in Section 1 of the Bid Proposal form.

AL = Allowance CF = Cubic Feet CY = Cubic Yard EA = Each LB = Pounds
 LF = Linear Foot LS = Lump Sum SF = Square Feet TON = Ton (2000 lbs)

BID ITEM NO.	ITEM DESCRIPTION	EST. QTY.	UNIT	UNIT COST	EXTENDED TOTAL AMOUNT
1	Mobilization	1	LS	\$	\$
2	Traffic Control	1	LS	\$	\$
3	Storm Water Erosion/Pollution Control Plan	1	LS	\$	\$
4	Class 2 Aggregate Base	190	TON	\$	\$
5	Remove and Replace Signs and Posts	2	EA	\$	\$
6	Reconstruct Sidewalk	6,350	SF	\$	\$
7	Reconstruct Curb and Gutter	736	LF	\$	\$
8	Reconstruct Driveway Approach	689	SF	\$	\$
9	Reconstruct ADA Ramp	12	EA	\$	\$
10	Adjust Utility to Grade	2	EA	\$	\$
11	Tree Removal	15	EA	\$	\$

* Final Pay Quantity

TOTAL BASE BID: Items 1 through 11 inclusive: \$ _____

Note: The amount entered as the "Total Base Bid" should be identical to the Base Bid amount entered in Section 1 of the Bid Proposal form.

BIDDER NAME: _____

END OF BID SCHEDULE

Noncollusion Declaration

TO BE EXECUTED BY BIDDER AND SUBMITTED WITH BID

The undersigned declares:

I am the _____ [title] of _____
[business name], the party making the foregoing bid.

The bid is not made in the interest of, or on behalf of, any undisclosed person, partnership, company, association, organization, or corporation. The bid is genuine and not collusive or sham. The bidder has not directly or indirectly induced or solicited any other bidder to put in a false or sham bid. The bidder has not directly or indirectly colluded, conspired, connived, or agreed with any bidder or anyone else to put in a sham bid, or to refrain from bidding. The bidder has not in any manner, directly or indirectly, sought by agreement, communication, or conference with anyone to fix the bid price of the bidder or any other bidder, or to fix any overhead, profit, or cost element of the bid price, or of that of any other bidder. All statements contained in the bid are true. The bidder has not, directly or indirectly, submitted his or her bid price or any breakdown thereof, or the contents thereof, or divulged information or data relative thereto, to any corporation, partnership, company, association, organization, bid depository, or to any member or agent thereof, to effectuate a collusive or sham bid, and has not paid and will not pay, any person or entity for such purpose.

Any person executing this declaration on behalf of a bidder that is a corporation, partnership, joint venture, limited liability company, limited liability partnership, or any other entity, hereby represents that he or she has full power to execute, and does execute, this declaration on behalf of the bidder.

This declaration is intended to comply with California Public Contract Code § 7106 and Title 23 U.S.C § 112.

I declare under penalty of perjury under the laws of the State of California that the foregoing is true and correct and that this declaration is executed on _____ [date], at _____ [city], _____ [state].

s/ _____

Name [print]

END OF NONCOLLUSION DECLARATION

Bid Bond

_____ (“Bidder”) has submitted a bid, dated _____, 2026 (“Bid”), to the City of Brentwood (“City”) for work on the Pavement Management Program 2026 (Concrete), CIP Project No. 336-31705 (“Project”). Under this duly executed bid bond (“Bid Bond”), Bidder as Principal and _____, its surety (“Surety”), are bound to City as obligee in the penal sum of ten percent of the maximum amount of the Bid (the “Bond Sum”). Bidder and Surety bind themselves and their respective heirs, executors, administrators, successors and assigns, jointly and severally, as follows:

1. **General.** If Bidder is awarded the Contract for the Project, Bidder will enter into the Contract with City in accordance with the terms of the Bid.
2. **Submittals.** Within ten days following issuance of the Notice of Potential Award to Bidder, Bidder must submit to City the following:
 - 2.1 **Contract.** The executed Contract, using the form provided by City in the Project contract documents (“Contract Documents”);
 - 2.2 **Payment Bond.** A payment bond for 100% of the maximum Contract Price, executed by a surety licensed to do business in the State of California using the Payment Bond form included with the Contract Documents;
 - 2.3 **Performance Bond.** A performance bond for 100% of the maximum Contract Price, executed by a surety licensed to do business in the State of California using the Performance Bond form included with the Contract Documents;
 - 2.4 **Insurance.** The insurance certificate(s) and endorsement(s) required by the Contract Documents;
 - 2.5 **Certificates of Reported Compliance.** Valid Certificates of Reported Compliance for its fleet and its listed Subcontractors, if applicable, in accordance with the In-Use Off-Road Diesel-Fueled Fleets Regulation (13 CCR § 2449 et seq.) (“Off-Road Regulation”), if the Project involves the use of vehicles subject to the Off-Road Regulation; and any other documents required by the Instructions to Bidders or Notice of Potential Award, including the submittal for local purchase and local labor information if required by the Instructions to Bidders, using the form provided with the Notice of Potential Award.
3. **Enforcement.** If Bidder fails to execute the Contract or to submit the bonds, insurance certificates, and valid Certificates of Reported Compliance as required by the Contract Documents, Surety guarantees that Bidder forfeits the Bond Sum to City. Any notice to Surety may be given in the manner specified in the Contract and delivered or transmitted to Surety as follows:

Attn: _____
Address: _____
City/State/Zip: _____
Phone: _____
Fax: _____
Email: _____

4. **Duration and Waiver.** If Bidder fulfills its obligations under Section 2, above, then this obligation will be null and void; otherwise, it will remain in full force and effect for 60 days

following the bid opening or until this Bid Bond is returned to Bidder, whichever occurs first.
Surety waives the provisions of Civil Code §§ 2819 and 2845.

This Bid Bond is entered into and effective on _____, 20_____.

SURETY:

Business Name

s/ _____

Date

Name, Title

(Attach Acknowledgment with Notary Seal and Power of Attorney)

BIDDER:

Business Name

s/ _____

Date

Name, Title

END OF BID BOND

Bidder's Questionnaire

**Pavement Management Program 2026 (Concrete)
CIP Project No. 336-31705**

Within 48 hours following a request by City, a bidder must submit to City a completed, signed Bidder's Questionnaire using this form and all required attachments, including clearly labeled additional sheets as needed. City may request the Questionnaire from one or more of the apparent low bidders following the bid opening, and may use the completed Questionnaire as part of its investigation to evaluate a bidder's qualifications for this Project. The Questionnaire must be filled out completely, accurately, and legibly. Any errors, omissions, or misrepresentations in completion of the Questionnaire may be grounds for rejection of the bid or termination of a Contract awarded pursuant to the bid.

Part A: General Information

Bidder Business Name: _____ ("Bidder")

Check One: Corporation (State of incorporation: _____)
 Partnership
 Sole Proprietorship
 Joint Venture of: _____
 Other: _____

Main Office Address and Phone: _____

Local Office Address and Phone: _____

Website Address: _____

Owner of Business: _____

Contact Name and Title: _____

Contact Phone and Email: _____

Bidder's California Contractor's License Number(s): _____

Bidder's DIR Registration Number: _____

Part B: Bidder Experience

1. How many years has Bidder been in business under its present business name? ____ years
2. Has Bidder completed projects similar in type and size to this Project as a general contractor?
____ Yes ____ No
3. Has Bidder ever been disqualified from a bid on grounds that it is not responsible, or otherwise disqualified or debarred from bidding under state or federal law?
____ Yes ____ No

If yes, provide additional information on a separate sheet regarding the disqualification or debarment, including the name and address of the agency or owner of the project, the type and size of the project, the reasons that Bidder was disqualified or debarred, and the month and year in which the disqualification or debarment occurred.

4. Has Bidder ever been terminated for cause, alleged default, or legal violation from a construction project, either as a general contractor or as a subcontractor?

_____ Yes _____ No

If yes, provide additional information on a separate sheet regarding the termination, including the name and address of the agency or owner of the subject project, the type and size of the project, whether Bidder was under contract as a general contractor or a subcontractor, the reasons that Bidder was terminated, and the month and year in which the termination occurred.

5. Provide information about Bidder's past projects performed as general contractor as follows:

- 5.1 Six most recently completed public works projects within the last three years;
- 5.2 Three largest completed projects within the last three years; and
- 5.3 Any project which is similar to this Project including scope and character of the work.

6. Use separate sheets to provide all of the following information for each project identified in response to the above three categories:

- 6.1 Project name, location, and description;
- 6.2 Owner (name, address, email, and phone number);
- 6.3 Prime contractor, if applicable (name, address, email, and phone number);
- 6.4 Architect or engineer (name, email, and phone number);
- 6.5 Project and/or construction manager (name, email, and phone number);
- 6.6 Scope of work performed (as general contractor or as subcontractor);
- 6.7 Initial contract price and final contract price (including change orders);
- 6.8 Original scheduled completion date and actual date of completion;
- 6.9 Time extensions granted (number of days);
- 6.10 Number and amount of stop notices or mechanic's liens filed;
- 6.11 Amount of any liquidated damages assessed against Bidder; and
- 6.12 Nature and resolution of any project-related claim, lawsuit, mediation, or arbitration involving Bidder.

Part C: Safety

1. Provide Bidder's Experience Modification Rate (EMR) for the last three years:

Year	EMR

2. Complete the following, based on information provided in Bidder's CalOSHA Form 300 or Form 300A, Annual Summary of Work-Related Illnesses and Injuries, from the most recent past calendar year:

- 2.1 Number of lost workday cases: _____
- 2.2 Number of medical treatment cases: _____
- 2.3 Number of deaths: _____

3. Has Bidder ever been cited, fined, or prosecuted by any local, state, or federal agency, including OSHA, CalOSHA, or EPA, for violation of any law, regulation, or requirements pertaining to health and safety?

_____ Yes _____ No

If yes, provide additional information on a separate sheet regarding each such citation, fine, or prosecution, including the name and address of the agency or owner of the project, the type and size of the project, the reasons for and nature of the citation, fine, or prosecution, and the month and year in which the incident giving rise to the citation, fine, or prosecution occurred.

4. Name, title, and email for person responsible for Bidder's safety program:

Name Title Email

Part D: Verification

In signing this document, I, the undersigned, declare that I am duly authorized to sign and submit this Bidder's Questionnaire on behalf of the named Bidder, and that all responses and information set forth in this Bidder's Questionnaire and accompanying attachments are, to the best of my knowledge, true, accurate and complete as of the date of submission. **I declare under penalty of perjury under the laws of the State of California that the foregoing is true and correct.**

Signature: _____ Date: _____

By: _____
Name and Title

END OF BIDDER'S QUESTIONNAIRE

Contract

This public works contract ("Contract") is entered into by and between the City of Brentwood ("City") and _____ ("Contractor"), for work on the Pavement Management Program 2026 (Concrete), CIP Project No. 336-31705 ("Project").

The parties agree as follows:

1. **Award of Contract.** In response to the Notice Inviting Bids, Contractor has submitted a Bid Proposal to perform the Work to construct the Project. On _____, 20____, City authorized award of this Contract to Contractor for the amount set forth in Section 4, below. City has elected to include the following Project alternate(s) in the Contract: No Alternates.
2. **Contract Documents.** The Contract Documents incorporated into this Contract include and are comprised of all of the documents listed below. The definitions provided in Article 1 of the General Conditions apply to all of the Contract Documents, including this Contract.
 - 2.1 Notice Inviting Bids;
 - 2.2 Instructions to Bidders;
 - 2.3 Addenda, if any;
 - 2.4 Bid Proposal and attachments thereto;
 - 2.5 Contract;
 - 2.6 Payment and Performance Bonds;
 - 2.7 General Conditions;
 - 2.8 Special Conditions;
 - 2.9 Project Plans and Specifications;
 - 2.10 Change Orders, if any;
 - 2.11 Notice of Potential Award;
 - 2.12 Notice to Proceed; and
 - 2.13 The following:
3. **Contractor's Obligations.** Contractor will perform all of the Work required for the Project, as specified in the Contract Documents. Contractor must provide, furnish, and supply all things necessary and incidental for the timely performance and completion of the Work, including all necessary labor, materials, supplies, tools, equipment, transportation, onsite facilities, and utilities, unless otherwise specified in the Contract Documents. Contractor must use its best efforts to diligently prosecute and complete the Work in a professional and expeditious manner and to meet or exceed the performance standards required by the Contract Documents.
4. **Payment.** As full and complete compensation for Contractor's timely performance and completion of the Work in strict accordance with the terms and conditions of the Contract Documents, City will pay Contractor \$ _____ ("Contract Price") for all of Contractor's direct and indirect costs to perform the Work, including all labor, materials, supplies, equipment, taxes, insurance, bonds and all overhead costs, in accordance with the payment provisions in the General Conditions.
5. **Time for Completion.** Contractor will fully complete the Work for the Project, meeting all requirements for Final Completion, within 70 calendar days from the start date set forth in the Notice to Proceed ("Contract Time"). By signing below, Contractor expressly waives any claim for delayed early completion.
6. **Liquidated Damages.** As further specified in Section 5.4 of the General Conditions, if Contractor fails to complete the Work within the Contract Time, City will assess liquidated

damages in the amount of \$2,500 per day for each day of unexcused delay in achieving Final Completion, and such liquidated damages may be deducted from City's payments due or to become due to Contractor under this Contract.

7. Labor Code Compliance.

7.1 General. This Contract is subject to all applicable requirements of Chapter 1 of Part 7 of Division 2 of the Labor Code, including requirements pertaining to wages, working hours and workers' compensation insurance, as further specified in Article 9 of the General Conditions.

7.2 Prevailing Wages. This Project is subject to the prevailing wage requirements applicable to the locality in which the Work is to be performed for each craft, classification or type of worker needed to perform the Work, including employer payments for health and welfare, pension, vacation, apprenticeship and similar purposes. Copies of these prevailing rates are available online at <http://www.dir.ca.gov/DLSR>.

7.3 DIR Registration. City may not enter into the Contract with a bidder without proof that the bidder and its Subcontractors are registered with the California Department of Industrial Relations to perform public work pursuant to Labor Code § 1725.5, subject to limited legal exceptions.

8. Workers' Compensation Certification. Pursuant to Labor Code § 1861, by signing this Contract, Contractor certifies as follows: "I am aware of the provisions of Labor Code § 3700 which require every employer to be insured against liability for workers' compensation or to undertake self-insurance in accordance with the provisions of that code, and I will comply with such provisions before commencing the performance of the Work on this Contract."

9. Conflicts of Interest. Contractor, its employees, Subcontractors, and agents may not have, maintain, or acquire a conflict of interest in relation to this Contract in violation of any City ordinance or requirement, or in violation of any California law, including Government Code § 1090 et seq., or the Political Reform Act, as set forth in Government Code § 81000 et seq. and its accompanying regulations. Any violation of this Section constitutes a material breach of the Contract.

10. Independent Contractor. Contractor is an independent contractor under this Contract and will have control of the Work and the means and methods by which it is performed. Contractor and its Subcontractors are not employees of City and are not entitled to participate in any health, retirement, or any other employee benefits from City.

11. Notice. Any notice, billing, or payment required by or pursuant to the Contract Documents must be made in writing, signed, dated, and sent to the other party by personal delivery, U.S. Mail, a reliable overnight delivery service, or by email as a PDF file. Notice is deemed effective upon delivery, except that service by U.S. Mail is deemed effective on the second working day after deposit for delivery. Notice for each party must be given as follows:

City: City of Brentwood
Engineering Department
150 City Park Way
Brentwood, CA 94513
925.516.5420
Attn: Brant Wilson, PE, Associate Civil Engineer
bwilson@brentwoodca.gov

Contractor:

Name: _____
Address: _____
City/State/Zip: _____
Phone: _____
Attn: _____
Email: _____
Copy to: _____

12. General Provisions.

- 12.1 Assignment and Successors.** Contractor may not assign its rights or obligations under this Contract, in part or in whole, without City’s written consent. This Contract is binding on Contractor’s and City’s lawful heirs, successors and permitted assigns.
- 12.2 Third Party Beneficiaries.** There are no intended third party beneficiaries to this Contract.
- 12.3 Governing Law and Venue.** This Contract will be governed by California law and venue will be in the Contra Costa County Superior Court, and no other place. Contractor waives any right it may have pursuant to Code of Civil Procedure § 394, to file a motion to transfer any action arising from or relating to this Contract to a venue outside of Contra Costa County, California.
- 12.4 Amendment.** No amendment or modification of this Contract will be binding unless it is in a writing duly authorized and signed by the parties to this Contract.
- 12.5 Integration.** This Contract and the Contract Documents incorporated herein, including authorized amendments or Change Orders thereto, constitute the final, complete, and exclusive terms of the agreement between City and Contractor.
- 12.6 Severability.** If any provision of the Contract Documents is determined to be illegal, invalid, or unenforceable, in whole or in part, the remaining provisions of the Contract Documents will remain in full force and effect.
- 12.7 Iran Contracting Act.** If the Contract Price exceeds \$1,000,000, Contractor certifies, by signing below, that it is not identified on a list created under the Iran Contracting Act, Public Contract Code § 2200 et seq. (the “Act”), as a person engaging in investment activities in Iran, as defined in the Act, or is otherwise expressly exempt under the Act.
- 12.8 Authorization.** Each individual signing below warrants that he or she is authorized to do so by the party that he or she represents, and that this Contract is legally binding on that party. If Contractor is a corporation, signatures from two officers of the corporation are required pursuant to California Corporations Code § 313.
- 12.9 Digital/Electronic Signatures.** Using a City-approved method, this Contract may be executed through the use of digital or electronic signatures in accordance with Government Code Section 16.5. The presence of an electronic signature on this Contract will be construed as the Parties’ consent to do business electronically.

[Signatures are on the following page.]

The parties agree to this Contract as witnessed by the signatures below:

CITY:

Approved as to form:

s/ _____

s/ _____

G. Harold Duffey, City Manager

_____, City Attorney

Name, Title

Name, Title

Date: _____

Date: _____

Attest:

s/ _____

Amanda McVey, City Clerk

Name, Title

Date: _____

CONTRACTOR:

Business Name

s/ _____

Seal:

Name, Title

Date: _____

Second Signature (See Section 12.8):

s/ _____

Name, Title

Date: _____

Contractor's California License Number(s) and Expiration Date(s)

END OF CONTRACT

Payment Bond

The City of Brentwood ("City") and _____ ("Contractor") have entered into a contract for work on the **Pavement Management Program 2026 (Concrete), CIP Project No. 336-31705 ("Project")**. The Contract is incorporated by reference into this Payment Bond ("Bond").

1. **General.** Under this Bond, Contractor as principal and _____, its surety ("Surety"), are bound to City as obligee in an amount not less than \$ _____, under California Civil Code § 9550 et seq., to ensure payment to authorized claimants. This Bond is binding on the respective successors, assigns, owners, heirs, or executors of Surety and Contractor.
2. **Surety's Obligation.** If Contractor or any of its Subcontractors fails to pay a person authorized in California Civil Code § 9100 to assert a claim against a payment bond, any amounts due under the Unemployment Insurance Code with respect to work or labor performed under the Contract, or any amounts required to be deducted, withheld, and paid over to the Employment Development Department from the wages of employees of Contractor and its Subcontractors under California Unemployment Insurance Code § 13020 with respect to the work and labor, then Surety will pay the obligation.
3. **Beneficiaries.** This Bond inures to the benefit of any of the persons named in California Civil Code § 9100, so as to give a right of action to those persons or their assigns in any suit brought upon this Bond. Contractor must promptly provide a copy of this Bond upon request by any person with legal rights under this Bond.
4. **Duration.** If Contractor promptly makes payment of all sums for all labor, materials, and equipment furnished for use in the performance of the Work required by the Contract, in conformance with the time requirements set forth in the Contract and as required by California law, Surety's obligations under this Bond will be null and void. Otherwise, Surety's obligations will remain in full force and effect.
5. **Waivers.** Surety waives any requirement to be notified of alterations to the Contract or extensions of time for performance of the Work under the Contract. Surety waives the provisions of Civil Code §§ 2819 and 2845. City waives the requirement of a new bond for any supplemental contract under Civil Code § 9550. Any notice to Surety may be given in the manner specified in the Contract and sent to Surety as follows:

Attn: _____
Address: _____
City/State/Zip: _____
Phone: _____
Email: _____

6. **Law and Venue.** This Bond will be governed by California law, and venue for any dispute pursuant to this Bond will be in the Contra Costa County Superior Court, and no other place. Surety will be responsible for City's attorneys' fees and costs in any action to enforce the provisions of this Bond.

[Signatures are on the following page.]

7. **Effective Date; Execution.** This Bond is entered into and is effective on _____, 2026.

SURETY:

Business Name

s/ _____

Date

Name, Title

(Attach Acknowledgment with Notary Seal and Power of Attorney)

CONTRACTOR:

Business Name

s/ _____

Date

Name, Title

APPROVED BY CITY:

City of Brentwood

s/ _____

Date

G. Harold Duffey, City Manager

Name, Title

END OF PAYMENT BOND

Performance Bond

The City of Brentwood ("City") and _____ ("Contractor") have entered into a contract for work on the **Pavement Management Program 2026 (Concrete), CIP Project No. 336-31705 ("Project")**. The Contract is incorporated by reference into this Performance Bond ("Bond").

1. **General.** Under this Bond, Contractor as principal and _____, its surety ("Surety"), are bound to City as obligee for an amount not less than \$_____ to ensure Contractor's faithful performance of its obligations under the Contract. This Bond is binding on the respective successors, assigns, owners, heirs, or executors of Surety and Contractor.
2. **Surety's Obligations.** Surety's obligations are co-extensive with Contractor's obligations under the Contract. If Contractor fully performs its obligations under the Contract, including its warranty obligations under the Contract, Surety's obligations under this Bond will become null and void. Otherwise, Surety's obligations will remain in full force and effect.
3. **Waiver.** Surety waives any requirement to be notified of and further consents to any alterations to the Contract made under the applicable provisions of the Contract Documents, including changes to the scope of Work or extensions of time for performance of Work under the Contract. Surety waives the provisions of Civil Code §§ 2819 and 2845.
4. **Application of Contract Balance.** Upon making a demand on this Bond for completion of the Work prior to acceptance of the Project, City will make the Contract Balance available to Surety for completion of the Work under the Contract. For purposes of this provision, the Contract Balance is defined as the total amount payable by City to Contractor as the Contract Price minus amounts already paid to Contractor, and minus any liquidated damages, credits, or back charges to which City is entitled under the terms of the Contract.
5. **Contractor Default.** Upon written notification from City of Contractor's termination for default under Article 13 of the Contract General Conditions, time being of the essence, Surety must act within the time specified in Article 13 to remedy the default through one of the following courses of action:
 - 5.1 Arrange for completion of the Work under the Contract by Contractor, with City's consent, but only if Contractor is in default solely due to its financial inability to complete the Work;
 - 5.2 Arrange for completion of the Work under the Contract by a qualified contractor acceptable to City, and secured by performance and payment bonds issued by an admitted surety as required by the Contract Documents, at Surety's expense; or
 - 5.3 Waive its right to complete the Work under the Contract and reimburse City the amount of City's costs to have the remaining Work completed.
6. **Surety Default.** If Surety defaults on its obligations under the Bond, City will be entitled to recover all costs it incurs due to Surety's default, including legal, design professional, or delay costs.
7. **Notice.** Any notice to Surety may be given in the manner specified in the Contract and sent to Surety as follows:

Attn: _____
Address: _____
City/State/Zip: _____
Phone: _____
Fax: _____
Email: _____

8. Law and Venue. This Bond will be governed by California law, and venue for any dispute pursuant to this Bond will be in the Contra Costa County Superior Court, and no other place. Surety will be responsible for City's attorneys' fees and costs in any action to enforce the provisions of this Bond.

9. Effective Date; Execution. This Bond is entered into and effective on _____, 20____.

SURETY:

Business Name

s/ _____

Date

Name, Title

(Attach Acknowledgment with Notary Seal and Power of Attorney)

CONTRACTOR:

Business Name

s/ _____

Date

Name, Title

APPROVED BY CITY:

City of Brentwood

s/ _____

Date

G. Harold Duffey, City Manager

Name, Title

END OF PERFORMANCE BOND

General Conditions

Article 1 - Definitions

Definitions. The following definitions apply to all of the Contract Documents unless otherwise indicated, e.g., additional definitions that apply solely to the Specifications or other technical documents. Defined terms and titles of documents are capitalized in the Contract Documents, with the exception of the following (in any tense or form): “day,” “furnish,” “including,” “install,” “work day,” or “working day.”

Allowance means a specific amount that must be included in the Bid Proposal for a specified purpose.

Article, as used in these General Conditions, means a numbered Article of the General Conditions, unless otherwise indicated by the context.

Change Order means a written document duly approved and executed by City, which changes the scope of Work, the Contract Price, or the Contract Time.

City means the municipality which has entered into the Contract with Contractor for performance of the Work, acting through its City Council, officers, employees, City Engineer, and any other authorized representatives.

City Engineer means the City Engineer for City and his or her authorized delegee(s).

Claim means a separate demand by Contractor for a change in the Contract Time or Contract Price, that has previously been submitted to City in accordance with the requirements of the Contract Documents, and which has been rejected by City, in whole or in part; a written demand by Contractor disputing a unilateral Change Order or a portion thereof; or a written demand by Contractor objecting to the amount of Final Payment.

Contract means the signed agreement between City and Contractor for performing the Work required for the Project, and all documents expressly incorporated therein.

Contract Documents means, collectively, all of the documents listed as such in Section 2 of the Contract, including the Notice Inviting Bids; the Instructions to Bidders; addenda, if any; the Bid Proposal and attachments thereto; the Contract; the Notice of Potential Award and Notice to Proceed; the payment and performance bonds; the General Conditions; the Special Conditions; the Project Plans and Specifications; any Change Orders; and any other documents which are clearly and unambiguously made part of the Contract Documents. The Contract Documents do not include Informational Documents provided for reference only, or documents that are intended solely to provide information regarding existing conditions.

Contract Price means the total compensation to be paid to Contractor for performance of the Work, as set forth in the Contract and as may be amended by Change Order or adjusted for an Allowance. The Contract Price is not subject to adjustment due to inflation or due to the increased cost of labor, material, supplies, or equipment following submission of the Bid Proposal.

Contract Time means the time specified for complete performance of the Work, as set forth in the Contract and as may be amended by Change Order.

Contractor means the individual, partnership, corporation, or joint venture that has signed the Contract with City to perform the Work.

Day means a calendar day unless otherwise specified.

Design Professional means the licensed individual(s) or firm(s) retained by City to provide architectural, engineering, or other design professional services for the Project. If no Design Professional has been retained for this Project, any reference to Design Professional is deemed to refer to the Engineer.

DIR means the California Department of Industrial Relations.

Drawings has the same meaning as Plans.

Engineer means the City Engineer for the City of Brentwood and their authorized delegees.

Excusable Delay is defined in Section 5.3(B), Excusable Delay.

Extra Work means new or unforeseen work added to the Project, as determined by the Engineer in his or her sole discretion, including Work that was not part of or incidental to the scope of the Work when the Contractor's bid was submitted; Work that is substantially different from the Work as described in the Contract Documents at bid time; or Work that results from a substantially differing and unforeseeable condition.

Final Completion means Contractor has fully completed all of the Work required by the Contract Documents to the City's satisfaction, including all punch list items and any required commissioning or training, and has provided the City with all required submittals, including the instructions and manuals, product warranties, and as-built drawings.

Final Payment means payment to Contractor of the unpaid Contract Price, including release of undisputed retention, less amounts withheld or deducted pursuant to the Contract Documents.

Furnish means to purchase and deliver for the Project.

Government Code Claim means a claim submitted pursuant to California Government Code § 900 et seq.

Hazardous Materials means any substance or material identified now or in the future as hazardous under any Laws, or any other substance or material that may be considered hazardous or otherwise subject to Laws governing handling, disposal, or cleanup.

Including, whether or not capitalized, means "including, but not limited to," unless the context clearly requires otherwise.

Inspector means the individual(s) or firm(s) retained or employed by City to inspect the workmanship, materials, and manner of construction of the Project and its components to ensure compliance with the Contract Documents and all Laws.

Install means to fix in place for materials, and to fix in place and connect for equipment.

Laws means all applicable local, state, and federal laws, regulations, rules, codes, ordinances, permits, orders, and the like enacted or imposed by or under the auspices of any governmental entity with jurisdiction over any of the Work or any performance of the Work, including health and safety requirements.

Non-Excusable Delay is defined in Section 5.3(D), Non-Excusable Delay.

Plans means the City-provided plans, drawings, details, or graphical depictions of the Project requirements, but does not include Shop Drawings.

Project means the public works project referenced in the Contract, as modified by any Project alternates elected by City, if any.

Project Manager means the individual designated by City to oversee and manage the Project on City's behalf and may include his or her authorized delegee(s) when the Project Manager is unavailable. If no Project Manager has been designated for this Project, any reference to Project Manager is deemed to refer to the Engineer.

Recoverable Costs is defined in Section 5.3(F), Recoverable Costs.

Request for Information or **RFI** means Contractor's written request for information about the Contract Documents, the Work or the Project, submitted to City in the manner and format specified by City.

Section, when capitalized in these General Conditions, means a numbered section or subsection of the General Conditions, unless the context clearly indicates otherwise.

Shop Drawings means drawings, plan details or other graphical depictions prepared by or on behalf of Contractor, and subject to City acceptance, which are intended to provide details for fabrication, installation, and the like, of items required by or shown in the Plans or Specifications.

Specialty Work means Work that must be performed by a specialized Subcontractor with the specified license or other special certification, and that the Contractor is not qualified to self-perform.

Specifications means the technical, text specifications describing the Project requirements, which are prepared for and incorporated into the Contract by or on behalf of City, and does not include the Contract, General Conditions or Special Conditions.

Subcontractor means an individual, partnership, corporation, or joint venture retained by Contractor directly or indirectly through a subcontract to perform a specific portion of the Work. The term Subcontractor applies to subcontractors of all tiers, unless otherwise indicated by the context. A third party such as a utility performing related work on the Project is not a Subcontractor, even if Contractor must coordinate its Work with the third party.

Technical Specifications has the same meaning as Specifications.

Work means all of the construction and services necessary for or incidental to completing the Project in conformance with the requirements of the Contract Documents.

Work Day or **Working Day**, whether or not capitalized, means a weekday when the City is open for business, and does not include holidays observed by the City.

Worksite means the place or places where the Work is performed, which includes, but may extend beyond the Project site, including separate locations for staging, storage, or fabrication.

Article 2 - Roles and Responsibilities

2.1 City.

(A) **City Council.** The City Council has final authority in all matters affecting the Project, except to the extent it has delegated authority to the Engineer.

(B) **Engineer.** The Engineer, acting within the authority conferred by the City Council, is responsible for administration of the Project on behalf of City, including

authority to provide directions to the Design Professional and to Contractor to ensure proper and timely completion of the Project. The Engineer's decisions are final and conclusive within the scope of his or her authority, including interpretation of the Contract Documents.

(C) **Project Manager.** The Project Manager assigned to the Project will be the primary point of contact for the Contractor and will serve as City's representative for daily administration of the Project on behalf of City. Unless otherwise specified, all of Contractor's communications to City (in any form) will go to or through the Project Manager. City reserves the right to reassign the Project Manager role at any time or to delegate duties to additional City representatives, without prior notice to or consent of Contractor.

(D) **Design Professional.** The Design Professional is responsible for the overall design of the Project and, to the extent authorized by City, may act on City's behalf to ensure performance of the Work in compliance with the Plans and Specifications, including any design changes authorized by Change Order. The Design Professional's duties may include review of Contractor's submittals, visits to any Worksite, inspecting the Work, evaluating test and inspection results, and participation in Project-related meetings, including any pre-construction conference, weekly meetings, and coordination meetings. The Design Professional's interpretation of the Plans or Specifications is final and conclusive.

2.2 Contractor.

(A) **General.** Contractor must provide all labor, materials, supplies, equipment, services, and incidentals necessary to perform and timely complete the Work in strict accordance with the Contract Documents, and in an economical and efficient manner in the best interests of City, and with minimal inconvenience to the public.

(B) **Responsibility for the Work and Risk of Loss.** Contractor is responsible for supervising and directing all aspects of the Work to facilitate the efficient and timely completion of the Work. Contractor is solely responsible for and required to exercise full control over the Work, including the construction means, methods, techniques, sequences, procedures, safety precautions and programs, and coordination of all portions of the Work with that of all other contractors and Subcontractors, except to the extent that the Contract Documents provide other specific instructions. Contractor's responsibilities extend to any plan, method or sequence suggested, but not required by City or specified in the Contract Documents. From the date of commencement of the Work until either the date on which City formally accepts the Project or the effective date of termination of the Contract, whichever is later, Contractor bears all risks of injury or damage to the Work and the materials and equipment delivered to any Worksite, by any cause including fire, earthquake, wind, weather, vandalism, or theft, subject to the limitations of Laws, including Public Contract Code § 7105.

(C) **Project Administration.** Contractor must provide sufficient and competent administration, staff, and skilled workforce necessary to perform and timely complete the Work in accordance with the Contract Documents. Before starting the Work, Contractor must designate in writing and provide complete contact information, including telephone numbers and email address, for the officer or employee in Contractor's organization who is to serve as Contractor's primary representative for the Project, and who has authority to act on Contractor's behalf. A Subcontractor may not serve as Contractor's primary representative.

(D) **On-Site Superintendent.** Contractor must, at all times during performance of the Work, provide a qualified and competent full-time superintendent acceptable to City,

and assistants as necessary, who must be physically present at the Project site while any aspect of the Work is being performed. The superintendent must have full authority to act and communicate on behalf of Contractor, and Contractor will be bound by the superintendent's communications to City. City's approval of the superintendent is required before the Work commences. If City is not satisfied with the superintendent's performance, City may request a qualified replacement of the superintendent. Failure to comply may result in temporary suspension of the Work, at Contractor's sole expense and with no extension of Contract Time, until an approved superintendent is physically present to supervise the Work. Contractor must provide written notice to City, as soon as practicable, before replacing the superintendent.

(E) **Standards.** Contractor must, at all times, ensure that the Work is performed in an efficient, skillful manner following best practices and in full compliance with the Contract Documents, Laws, and applicable manufacturer's recommendations. Contractor has a material and ongoing obligation to provide true and complete information, to the best of its knowledge, with respect to all records, documents, or communications pertaining to the Project, including oral or written reports, statements, certifications, Change Order requests, or Claims.

(F) **Meetings.** Contractor, its project manager, superintendent and any primary Subcontractors requested by City, must attend a pre-construction conference, if requested by City, as well as weekly Project progress meetings scheduled with City. If applicable, Contractor may also be required to participate in coordination meetings with other parties relating to other work being performed on or near the Project site or in relation to the Project, including work or activities performed by City, other contractors, or other utility owners.

(G) **Construction Records.** Contractor will maintain up-to-date, thorough, legible, and dated daily job reports, which document all significant activity on the Project for each day that Work is performed on the Project. The daily report for each day must include the number of workers at the Project site; primary Work activities; major deliveries; problems encountered, including injuries, if any; weather and site conditions; and delays, if any. Contractor will take date and time-stamped photographs to document general progress of the Project, including site conditions prior to construction activities, before and after photographs at offset trench laterals, existing improvements and utilities, damage and restoration. Contractor will maintain copies of all subcontracts, Project-related correspondence with Subcontractors, and records of meetings with Subcontractors. Upon request by the City, Contractor will permit review of and/or provide copies of any of these construction records.

(H) **Responsible Party.** Contractor is solely responsible to City for the acts or omissions of any Subcontractors, or any other party or parties performing portions of the Work or providing equipment, materials or services for or on behalf of Contractor or the Subcontractors. Upon City's written request, Contractor must promptly and permanently remove from the Project, at no cost to City, any employee or Subcontractor or employee of a Subcontractor who the Engineer has determined to be incompetent, intemperate or disorderly, or who has failed or refused to perform the Work as required under the Contract Documents.

(I) **Correction of Defects.** Contractor must promptly correct, at Contractor's sole expense, any Work that is determined by City to be deficient or defective in any way, including workmanship, materials, parts, or equipment. Workmanship, materials, parts, or equipment that do not conform to the requirements under the Contract Documents, as determined by City, will be considered defective and subject to rejection. Contractor must also promptly correct, at Contractor's sole expense, any Work performed beyond the lines and grades shown on the Plans or established by City, and any Extra Work

performed without City's prior written approval. If Contractor fails to correct or to take reasonable steps toward correcting defective Work within five days following notice from City, or within the time specified in City's notice to correct, City may elect to have the defective Work corrected by its own forces or by a third party, in which case the cost of correction will be deducted from the Contract Price. If City elects to correct defective Work due to Contractor's failure or refusal to do so, City or its agents will have the right to take possession of and use any equipment, supplies, or materials available at the Project site or any Worksite on City property, in order to effectuate the correction, at no extra cost to City. Contractor's warranty obligations under Section 11.2, Warranty, will not be waived nor limited by City's actions to correct defective Work under these circumstances. Alternatively, City may elect to retain defective Work, and deduct the difference in value, as determined by the Engineer, from payments otherwise due to Contractor. This paragraph applies to any defective Work performed by Contractor during the one-year warranty period under Section 11.2.

(J) **Contractor's Records.** Contractor must maintain all of its records relating to the Project in any form, including paper documents, photos, videos, electronic records, approved samples, and the construction records required pursuant to paragraph (G), above. Project records subject to this provision include complete Project cost records and records relating to preparation of Contractor's bid, including estimates, take-offs, and price quotes or bids.

(1) Contractor's cost records must include all supporting documentation, including original receipts, invoices, and payroll records, evidencing its direct costs to perform the Work, including, but not limited to, costs for labor, materials, and equipment. Each cost record should include, at a minimum, a description of the expenditure with references to the applicable requirements of the Contract Documents, the amount actually paid, the date of payment, and whether the expenditure is part of the original Contract Price, related to an executed Change Order, or otherwise categorized by Contractor as Extra Work. Contractor's failure to comply with this provision as to any claimed cost operates as a waiver of any rights to recover the claimed cost.

(2) Contractor must continue to maintain its Project-related records in an organized manner for a period of five years after City's acceptance of the Project or following Contract termination, whichever occurs first. Subject to prior notice to Contractor, City is entitled to inspect or audit any of Contractor's records relating to the Project during Contractor's normal business hours. Contractor's records may also be subject to examination and audit by the California State Auditor, pursuant to Government Code § 8546.7. The record-keeping requirements set forth in this subsection 2.2(J) will survive expiration or termination of the Contract.

(K) **Copies of Project Documents.** Contractor and its Subcontractors must keep copies, at the Project site, of all Work-related documents, including the Contract, permit(s), Plans, Specifications, addenda, Contract amendments, Change Orders, RFIs and RFI responses, Shop Drawings, as-built drawings, schedules, daily records, testing and inspection reports or results, and any related written interpretations. These documents must be available to City for reference at all times during construction of the Project.

2.3 Subcontractors.

(A) **General.** All Work which is not performed by Contractor with its own forces must be performed by Subcontractors. City reserves the right to approve or reject any and all Subcontractors proposed to perform the Work, for reasons including the Subcontractor's

poor reputation, lack of relevant experience, financial instability, and lack of technical ability or adequate trained workforce. Each Subcontractor must obtain a City business license before performing any Work.

(B) **Contractual Obligations.** Contractor must require each Subcontractor to comply with the provisions of the Contract Documents as they apply to the Subcontractor's portion(s) of the Work, including the generally applicable terms of the Contract Documents, and to likewise bind their subcontractors. Contractor will provide that the rights that each Subcontractor may have against any manufacturer or supplier for breach of warranty or guarantee relating to items provided by the Subcontractor for the Project, will be assigned to City. Nothing in these Contract Documents creates a contractual relationship between a Subcontractor and City, but City is deemed to be a third-party beneficiary of the contract between Contractor and each Subcontractor.

(C) **Termination.** If the Contract is terminated, each Subcontractor's agreement must be assigned by Contractor to City, subject to the prior rights of any surety, but only if and to the extent that City accepts, in writing, the assignment by written notification, and assumes all rights and obligations of Contractor pursuant to each such subcontract agreement.

(D) **Substitution of Subcontractor.** If Contractor requests substitution of a listed Subcontractor under Public Contract Code § 4107, Contractor is solely responsible for all costs City incurs in responding to the request, including legal fees and costs to conduct a hearing, and any increased subcontract cost to perform the Work that was to be performed by the listed Subcontractor. If City determines that a Subcontractor is unacceptable to City based on the Subcontractor's failure to satisfactorily perform its Work, or for any of the grounds for substitution listed in Public Contract Code § 4107(a), City may request removal of the Subcontractor from the Project. Upon receipt of a written request from City to remove a Subcontractor pursuant to this paragraph, Contractor will immediately remove the Subcontractor from the Project and, at no further cost to City, will either (1) self-perform the remaining Work to the extent that Contractor is duly licensed and qualified to do so, or (2) substitute a Subcontractor that is acceptable to City, in compliance with Public Contract Code § 4107, as applicable.

2.4 Coordination of Work.

(A) **Concurrent Work.** City reserves the right to perform, have performed, or permit performance of other work on or adjacent to the Project site while the Work is being performed for the Project. Contractor is responsible for coordinating its Work with other work being performed on or adjacent to the Project site, including by any utility companies or agencies, and must avoid hindering, delaying, or interfering with the work of other contractors, individuals, or entities, and must ensure safe and reasonable site access and use as required or authorized by City. To the full extent permitted by law, Contractor must hold harmless and indemnify City against any and all claims arising from or related to Contractor's avoidable, negligent, or willful hindrance of, delay to, or interference with the work of any utility company or agency or another contractor or subcontractor.

(B) **Coordination.** If Contractor's Work will connect or interface with work performed by others, Contractor is responsible for independently measuring and visually inspecting such work to ensure a correct connection and interface. Contractor is responsible for any failure by Contractor or its Subcontractors to confirm measurements before proceeding with connecting Work. Before proceeding with any portion of the Work affected by the construction or operations of others, Contractor must give the Project Manager prompt written notification of any defects Contractor discovers which will prevent the proper execution of the Work. Failure to give notice of any known or reasonably discoverable

defects will be deemed acknowledgement by Contractor that the work of others is not defective and will not prevent the proper execution of the Work. Contractor must also promptly notify City if work performed by others, including work or activities performed by City's own forces, is operating to hinder, delay, or interfere with Contractor's timely performance of the Work. City reserves the right to backcharge Contractor for any additional costs incurred due to Contractor's failure to comply with the requirements in this Section 2.4.

2.5 Submittals. Unless otherwise specified, Contractor must submit to the Engineer for review and acceptance, all schedules, Shop Drawings, samples, product data, and similar submittals required by the Contract Documents, or upon request by the Engineer. Unless otherwise specified, all submittals, including Requests for Information, are subject to the general provisions of this Section, as well as specific submittal requirements that may be included elsewhere in the Contract Documents, including the Special Conditions or Specifications. The Engineer may require submission of a submittal schedule at or before a pre-construction conference, as may be specified in the Notice to Proceed.

(A) **General.** Contractor is responsible for ensuring that its submittals are accurate and conform to the Contract Documents.

(B) **Time and Manner of Submission.** Contractor must ensure that its submittals are prepared and delivered in a manner consistent with the current City-accepted schedule for the Work and within the applicable time specified in the Contract Documents, or if no time is specified, in such time and sequence so as not to delay the performance of the Work or completion of the Project.

(C) **Required Contents.** Each submittal must include the Project name and contract number, Contractor's name and address, the name and address of any Subcontractor or supplier involved with the submittal, the date, and references to applicable Specification section(s) and/or drawing and detail number(s).

(D) **Required Corrections.** If corrections are required, Contractor must promptly make and submit any required corrections as specified in full conformance with the requirements of this Section, or other requirements that apply to that submittal.

(E) **Effect of Review and Acceptance.** Review and acceptance of a submittal by City will not relieve Contractor from complying with the requirements of the Contract Documents. Contractor is responsible for any errors in any submittal, and review or acceptance of a submittal by City is not an assumption of risk or liability by City.

(F) **Enforcement.** Any Work performed or any material furnished, installed, fabricated or used without City's prior acceptance of a required submittal is performed or provided at Contractor's risk, and Contractor may be required to bear the costs incident thereto, including the cost of removing and replacing such Work, repairs to other affected portions of the Work or material, and the cost of additional time or services required of City, including costs for the Design Professional, Project Manager, or Inspector.

(G) **Excessive RFIs.** A RFI will be considered excessive or unnecessary if City determines that the explanation or response to the RFI is clearly and unambiguously discernable from the Contract Documents. City's costs to review and respond to excessive or unnecessary RFIs may be deducted from payments otherwise due to Contractor.

2.6 Shop Drawings. When Shop Drawings are required by the Specifications or requested by the Engineer, they must be prepared according to best practices at Contractor's expense. The Shop Drawings must be of a size and scale to clearly show all necessary

details. Unless otherwise specified by City, Shop Drawings must be provided to the Engineer for review and acceptance at least 30 days before the Work will be performed. If City requires changes, the corrected Shop Drawings must be resubmitted to the Engineer for review within the time specified by the Engineer. For all Project components requiring Shop Drawings, Contractor will not furnish materials or perform any Work until the Shop Drawings for those components are accepted by City. Contractor is responsible for any errors or omissions in the Shop Drawings, shop fits and field corrections; any deviations from the Contract Documents; and for the results obtained by the use of Shop Drawings. Acceptance of Shop Drawings by City does not relieve Contractor of Contractor's responsibility.

- 2.7 Access to Work.** Contractor must afford prompt and safe access to any Worksite by City and its employees, agents, or consultants authorized by City; and upon request by City, Contractor must promptly arrange for City representatives to visit or inspect manufacturing sites or fabrication facilities for items to be incorporated into the Work.
- 2.8 Personnel.** Contractor and its Subcontractors must employ only competent and skillful personnel to perform the Work. Contractor and its Subcontractor's supervisors, security or safety personnel, and employees who have unescorted access to the Project site must possess proficiency in English sufficient to read, understand, receive, and implement oral or written communications or instructions relating to their respective job functions, including safety and security requirements. Upon written notification from the Engineer, Contractor and its Subcontractors must immediately discharge any personnel who are incompetent, disorderly, disruptive, threatening, abusive, or profane, or otherwise refuse or fail to comply with the requirements of the Contract Documents or Laws, including Laws pertaining to health and safety. Any such discharged personnel may not be re-employed or permitted on the Project in any capacity without City's prior written consent.

Article 3 - Contract Documents

3.1 Interpretation of Contract Documents.

(A) **Plans and Specifications.** The Plans and Specifications included in the Contract Documents are complementary. If Work is shown on one but not on the other, Contractor must perform the Work as though fully described on both, consistent with the Contract Documents and reasonably inferable from them as being necessary to produce the indicated results. The Plans and Specifications are deemed to include and require everything necessary and reasonably incidental to completion of the Work, whether or not particularly mentioned or shown. Contractor must perform all Work and services and supply all things reasonably related to and inferable from the Contract Documents. In the event of a conflict between the Plans and Specifications, the Specifications will control, unless the drawing(s) at issue are dated later than the Specification(s) at issue. Detailed drawings take precedence over general drawings, and large-scale drawings take precedence over smaller scale drawings. Any arrangement or division of the Plans and Specifications into sections is for convenience and is not intended to limit the Work required by separate trades. A conclusion presented in the Plans or Specifications is only a recommendation. Actual locations and depths must be determined by Contractor's field investigation. Contractor may request access to underlying or background information in City's possession that is necessary for Contractor to form its own conclusions.

(B) **Duty to Notify and Seek Direction.** If Contractor becomes aware of a changed condition in the Project, or of any ambiguity, conflict, inconsistency, discrepancy, omission, or error in the Contract Documents, including the Plans or Specifications, Contractor must promptly submit a Request for Information to the Engineer and wait for a response from City before proceeding further with the related Work. The RFI must notify

City of the issue and request clarification, interpretation or direction. The Engineer's clarification, interpretation or direction will be final and binding on Contractor. If Contractor proceeds with the related Work before obtaining City's response, Contractor will be responsible for any resulting costs, including the cost of correcting any incorrect or defective Work that results. Timely submission of a clear and complete RFI is essential to avoiding delay. Delay resulting from Contractor's failure to submit a timely and complete RFI to the Engineer is Non-Excusable Delay. If Contractor believes that City's response to an RFI justifies a change to the Contract Price or Contract Time, Contractor must perform the Work as directed, but may submit a timely Change Order request in accordance with the Contract Documents. (See Articles 5 and 6.)

(C) **Figures and Dimensions.** Figures control over scaled dimensions.

(D) **Technical or Trade Terms.** Any terms that have well-known technical or trade meanings will be interpreted in accordance with those meanings, unless otherwise specifically defined in the Contract Documents.

(E) **Measurements.** Contractor must verify all relevant measurements in the Contract Documents and at the Project site before ordering any material or performing any Work, and will be responsible for the correctness of those measurements or for costs that could have been avoided by independently verifying measurements.

(F) **Compliance with Laws.** The Contract Documents are intended to comply with Laws and will be interpreted to comply with Laws.

3.2 Order of Precedence. Information included in one Contract Document but not in another will not be considered a conflict or inconsistency. Unless otherwise specified in the Special Conditions, in case of any conflict or inconsistency among the Contract Documents, the following order of precedence will apply, beginning from highest to lowest, with the most recent version taking precedent over an earlier version:

- (A) Change Orders;
- (B) Addenda;
- (C) Contract;
- (D) Notice to Proceed;
- (E) Attachment B – Federal Contract Requirements (only if used);
- (F) Special Conditions;
- (G) General Conditions;
- (H) Payment and Performance Bonds;
- (I) Specifications;
- (J) Plans;
- (K) Notice of Potential Award;
- (L) Notice Inviting Bids;
- (M) Attachment A – Federal Bidding Requirements (only if used);
- (N) Instructions to Bidders;
- (O) Contractor's Bid Proposal and attachments;
- (P) the City's standard specifications, as applicable; and
- (Q) Any generic documents prepared by and on behalf of a third party, that were not prepared specifically for this Project, such as the Caltrans Standard Specifications or Caltrans Special Provisions.

3.3 Caltrans Standard Specifications. Any reference to or incorporation of the Standard Specifications of the State of California, Department of Transportation ("Caltrans"), including "Standard Specifications," "Caltrans Specifications," "State Specifications," or "CSS," means the most current edition of Caltrans' Standard Specifications, unless otherwise specified ("Caltrans Standard Specifications"), including the most current

amendments as of the date that Contractor's bid was submitted for this Project. The following provisions apply to use of or reference to the Caltrans Standard Specifications or Special Provisions:

(A) **Limitations.** The "General Provisions" of the Caltrans Standard Specifications, i.e., sections 1 through 9, do not apply to these Contract Documents with the exception of any specific provisions, if any, which are expressly stated to apply to these Contract Documents.

(B) **Conflicts or Inconsistencies.** If there is a conflict or inconsistency between any provision in the Caltrans Standard Specifications or Special Provisions and a provision of these Contract Documents, as determined by City, the provision in the Contract Documents will govern.

(C) **Meanings.** Terms used in the Caltrans Standard Specifications or Special Provisions are to be interpreted as follows:

(1) Any reference to the "Engineer" is deemed to mean the City Engineer.

(2) Any reference to the "Special Provisions" is deemed to mean the Special Conditions, unless the Caltrans Special Provisions are expressly included in the Contract Documents listed in Section 2 of the Contract.

(3) Any reference to the "Department" or "State" is deemed to mean City.

3.4 Informational Documents. Contractor is responsible for the careful review of any document, study, or report provided by City or appended to the Contract Documents solely for informational purposes and identified as "Informational Documents." Nothing in any document, study, or report so appended and identified is intended to supplement, alter, or void any provision of the Contract Documents. Contractor is advised that City or its representatives may be guided by information or recommendations included in such Informational Documents, particularly when making determinations as to the acceptability of proposed materials, methods, or changes in the Work. Any record drawings or similar final or accepted drawings or maps that are not part of the Contract Documents are deemed to be for informational purposes only. The provisions of the Contract Documents are not modified by any perceived or actual conflict with provisions in any Informational Document that is provided for reference only.

3.5 Current Versions. Unless otherwise specified by City, any reference to standard specifications, technical specifications, or any City or state codes or regulations means the latest specification, code, or regulation in effect on the date that bids were due.

3.6 Conformed Copies. If City prepares a conformed set of the Contract Documents following award of the Contract, it will provide Contractor with two hard copy (paper) sets and one copy of the electronic file in PDF format. It is Contractor's responsibility to ensure that all Subcontractors, including fabricators, are provided with the conformed set of the Contract Documents at Contractor's sole expense.

3.7 Ownership. No portion of the Contract Documents may be used for any purpose other than construction of the Project, without prior written consent from City. Contractor is deemed to have conveyed the copyright in any designs, drawings, specifications, Shop Drawings, or other documents (in paper or electronic form) developed by Contractor for the Project, and City will retain all rights to such works, including the right to possession.

Article 4 - Bonds, Indemnity, and Insurance

- 4.1 Payment and Performance Bonds.** Within ten days following issuance of the Notice of Potential Award, Contractor is required to provide a payment bond and a performance bond, each in the penal sum of not less than 100% of the Contract Price, and each executed by Contractor and its surety using the bond forms included with the Contract Documents.
- (A) **Surety.** Each bond must be issued and executed by a surety admitted in California. If an issuing surety cancels the bond or becomes insolvent, within seven days following written notice from City, Contractor must substitute a surety acceptable to City. If Contractor fails to substitute an acceptable surety within the specified time, City may, at its sole discretion, withhold payment from Contractor until the surety is replaced to City's satisfaction, or terminate the Contract for default.
- (B) **Supplemental Bonds for Increase in Contract Price.** If the Contract Price increases during construction by five percent or more over the original Contract Price, Contractor must provide supplemental or replacement bonds within ten days of written notice from City pursuant to this Section, covering 100% of the increased Contract Price and using the bond forms included with the Contract Documents.
- 4.2 Indemnity.** To the fullest extent permitted by law, Contractor must indemnify, defend, and hold harmless City, its Council, officers, officials, employees, agents, volunteers, and consultants (individually, an "Indemnitee," and collectively the "Indemnitees") from and against any and all liability, loss, damage, claims, causes of action, demands, charges, fines, costs, and expenses (including, without limitation, attorney fees, expert witness fees, paralegal fees, and fees and costs of litigation or arbitration) (collectively, "Liability") of every nature arising out of or in connection with the acts or omissions of Contractor, its employees, Subcontractors, representatives, or agents, in bidding or performing the Work or in failing to comply with any obligation of Contractor under the Contract, except such Liability caused by the active negligence, sole negligence, or willful misconduct of an Indemnitee. This indemnity requirement applies to any Liability arising from alleged defects in the content or manner of submission of Contractor's bid for the Contract. Contractor's failure or refusal to timely accept a tender of defense pursuant to this Contract will be deemed a material breach of the Contract. City will timely notify Contractor upon receipt of any third-party claim relating to the Contract, as required by Public Contract Code § 9201. Contractor waives any right to express or implied indemnity against any Indemnitee. Contractor's indemnity obligations under this Contract will survive the expiration or any early termination of the Contract.
- 4.3 Insurance.** No later than ten days following issuance of the Notice of Potential Award, Contractor must procure and provide proof of the insurance coverage required by this Section in the form of certificates and endorsements acceptable to City. The required insurance must cover the activities of Contractor and its Subcontractors relating to or arising from the performance of the Work, and must remain in full force and effect at all times during the period covered by the Contract, through the date of City's acceptance of the Project. All required insurance must be issued by a company licensed to do business in the State of California, and each such insurer must have an A.M. Best's financial strength rating of "A" or better and a financial size rating of "VIII" or better. If Contractor fails to provide any of the required coverage in full compliance with the requirements of the Contract Documents, City may, at its sole discretion, purchase such coverage at Contractor's expense and deduct the cost from payments due to Contractor, or terminate the Contract for default. The procurement of the required insurance will not be construed to limit Contractor's liability under this Contract or to fulfill Contractor's indemnification obligations under this Contract.

(A) **Policies and Limits.** The following insurance policies and limits are required for this Contract, unless otherwise specified in the Special Conditions:

(1) **Commercial General Liability (“CGL”) Insurance:** The CGL insurance policy must be issued on an occurrence basis, written on a comprehensive general liability form, and must include coverage for liability arising from Contractor’s or its Subcontractor’s acts or omissions in the performance of the Work, including contractor’s protective coverage, contractual liability, products and completed operations, and broad form property damage, with limits of at least \$5,000,000 per occurrence and at least \$4,000,000 general aggregate. The CGL insurance coverage may be arranged under a single policy for the full limits required or by a combination of underlying policies with the balance provided by excess or umbrella policies, provided each such policy complies with the requirements set forth in this Section, including required endorsements. This policy does not exclude explosion, collapse, underground excavation hazard, or removal of lateral support.

(2) **Automobile Liability Insurance:** The automobile liability insurance policy must provide coverage of at least \$2,000,000 combined single-limit per accident for bodily injury, death, or property damage, including hired and non-owned auto liability.

(3) **Workers’ Compensation Insurance and Employer’s Liability:** The workers’ compensation and employer’s liability insurance policy must comply with the requirements of the California Labor Code, providing coverage of at least \$1,000,000 or as otherwise required by the statute. If Contractor is self-insured, Contractor must provide its Certificate of Permission to Self-Insure, duly authorized by the DIR.

(4) **Pollution Liability Insurance:** The pollution liability insurance policy must be issued on an occurrence basis, providing coverage of at least \$2,000,000 for all loss arising out of claims for bodily injury, death, property damage, or environmental damage caused by pollution conditions resulting from the Work.

(5) **Builder’s Risk Insurance:** The builder’s risk insurance policy must be issued on an occurrence basis, for all-risk or “all perils” coverage on a 100% completed value basis on the insurable portion of the Project for the benefit of City.

(6) The inclusion of more than one insured will not operate to impair the rights of one insured against another, and the coverages afforded will apply as though separate policies have been issued to each insured.

(B) **Notice.** Each certificate of insurance must state that the coverage afforded by the policy or policies will not be reduced, cancelled or allowed to expire without at least 30 days advance written notice to City, unless due to non-payment of premiums, in which case ten days advance written notice must be made to City.

(C) **Waiver of Subrogation.** Each required policy must include an endorsement providing that the carrier will waive any right of subrogation it may have against City.

(D) **Required Endorsements.** The CGL policy, automobile liability policy, pollution liability policy, and builder’s risk policy must include the following specific endorsements:

(1) The City, including its Council, officials, officers, employees, agents, volunteers and consultants (collectively, “Additional Insured”) must be named as an additional insured for all liability arising out of the operations by or on behalf of

the named insured, and the policy must protect the Additional Insured against any and all liability for personal injury, death or property damage or destruction arising directly or indirectly in the performance of the Contract. The additional insured endorsement must be provided using ISO form CG 20 10 11 85 or equivalent form(s) approved by the City.

(2) The inclusion of more than one insured will not operate to impair the rights of one insured against another, and the coverages afforded will apply as though separate policies have been issued to each insured.

(3) The insurance provided by Contractor is primary and no insurance held or owned by any Additional Insured may be called upon to contribute to a loss.

(4) This policy does not exclude explosion, collapse, underground excavation hazard, or removal of lateral support.

(E) **Contractor's Responsibilities.** This Section 4.3 establishes the minimum requirements for Contractor's insurance coverage in relation to this Project, but is not intended to limit Contractor's ability to procure additional or greater coverage. Contractor is responsible for its own risk assessment and needs and is encouraged to consult its insurance provider to determine what coverage it may wish to carry beyond the minimum requirements of this Section. Contractor is solely responsible for the cost of its insurance coverage, including premium payments, deductibles, or self-insured retentions, and no Additional Insured will be responsible or liable for any of the cost of Contractor's insurance coverage.

(F) **Deductibles and Self-Insured Retentions.** Any deductibles or self-insured retentions that apply to the required insurance (collectively, "deductibles") in excess of \$100,000 are subject to approval by the City's Risk Manager, acting in his or her sole discretion, and must be declared by Contractor when it submits its certificates of insurance and endorsements pursuant to this Section 4.3. If the City's Risk Manager determines that the deductibles are unacceptably high, at City's option, Contractor must either reduce or eliminate the deductibles as they apply to City and all required Additional Insured; or must provide a financial guarantee, to City's satisfaction, guaranteeing payment of losses and related investigation, claim administration, and legal expenses.

(G) **Subcontractors.** Contractor must ensure that each Subcontractor is required to maintain the same insurance coverage required under this Section 4.3, with respect to its performance of Work on the Project, including those requirements related to the Additional Insureds and waiver of subrogation, but excluding pollution liability or builder's risk insurance unless otherwise specified in the Special Conditions. A Subcontractor may be eligible for reduced insurance coverage or limits, but only to the extent approved in writing in advance by the City's Risk Manager. Contractor must confirm that each Subcontractor has complied with these insurance requirements before the Subcontractor is permitted to begin Work on the Project. Upon request by the City, Contractor must provide certificates and endorsements submitted by each Subcontractor to prove compliance with this requirement. The insurance requirements for Subcontractors do not replace or limit the Contractor's insurance obligations.

Article 5 - Contract Time

5.1 Time is of the Essence. Time is of the essence in Contractor's performance and completion of the Work, and Contractor must diligently prosecute the Work and complete it within the Contract Time.

(A) **General.** Contractor must commence the Work on the date indicated in the Notice to Proceed and must fully complete the Work in strict compliance with all requirements of the Contract Documents and within the Contract Time. Contractor may not begin performing the Work before the date specified in the Notice to Proceed.

(B) **Authorization.** Contractor is not entitled to compensation or credit for any Work performed before the date specified in the Notice to Proceed, with the exception of any schedules, submittals, or other requirements, if any, that must be provided or performed before issuance of the Notice to Proceed.

(C) **Rate of Progress.** Contractor and its Subcontractors must, at all times, provide workers, materials, and equipment sufficient to maintain the rate of progress necessary to ensure full completion of the Work within the Contract Time. If City determines that Contractor is failing to prosecute the Work at a sufficient rate of progress, City may, in its sole discretion, direct Contractor to provide additional workers, materials, or equipment, or to work additional hours or days without additional cost to City, in order to achieve a rate of progress satisfactory to City. If Contractor fails to comply with City's directive in this regard, City may, at Contractor's expense, separately contract for additional workers, materials, or equipment or use City's own forces to achieve the necessary rate of progress. Alternatively, City may terminate the Contract based on Contractor's default.

5.2 Schedule Requirements. Contractor must prepare all schedules using standard, commercial scheduling software acceptable to the Engineer, and must provide the schedules in electronic and paper form as requested by the Engineer. In addition to the general scheduling requirements set forth below, Contractor must also comply with any scheduling requirements included in the Special Conditions or in the Technical Specifications.

(A) **Baseline (As-Planned) Schedule.** Within ten calendar days following City's issuance of the Notice to Proceed (or as otherwise specified in the Notice to Proceed), Contractor must submit to City for review and acceptance a baseline (as-planned) schedule using critical path methodology showing in detail how Contractor plans to perform and fully complete the Work within the Contract Time, including labor, equipment, materials, and fabricated items. The baseline schedule must show the order of the major items of Work and the dates of start and completion of each item, including when the materials and equipment will be procured. The schedule must also include the work of all trades, reflecting anticipated labor or crew hours and equipment loading for the construction activities, and must be sufficiently comprehensive and detailed to enable progress to be monitored on a day-by-day basis. For each activity, the baseline schedule must be dated, provided in the format specified in the Contract Documents or as required by City, and must include, at a minimum, a description of the activity, the start and completion dates of the activity, and the duration of the activity.

(1) **Specialized Materials Ordering.** Within five calendar days following issuance of the Notice to Proceed, Contractor must order any specialized material or equipment for the Work that is not readily available from material suppliers. Contractor must also retain documentation of the purchase order date(s).

(B) **City's Review of Schedules.** City will review and may note exceptions to the baseline schedule, and to the progress schedules submitted as required below, to assure completion of the Work within the Contract Time. Contractor is solely responsible for resolving any exceptions noted in a schedule and, within seven days, must correct the schedule to address the exceptions. City's review or acceptance of Contractor's schedules will not operate to waive or limit Contractor's duty to complete the Project within the Contract Time, nor to waive or limit City's right to assess liquidated damages for Contractor's unexcused failure to do so.

(C) **Progress Schedules.** After City accepts the final baseline schedule with no exceptions, Contractor must submit an updated progress schedule and three-week look-ahead schedule, in the format specified by City, for review and acceptance with each application for a progress payment, or when otherwise specified by City, until completion of the Work. The updated progress schedule must: show how the actual progress of the Work as constructed to date compares to the baseline schedule; reflect any proposed changes in the construction schedule or method of operations, including to achieve Project milestones within the Contract Time; and identify any actual or potential impacts to the critical path. Contractor must also submit periodic reports to City of any changes in the projected material or equipment delivery dates for the Project.

(1) *Float.* The progress schedule must show early and late completion dates for each task. The number of days between those dates will be designated as the "float." Any float belongs to the Project and may be allocated by the Engineer to best serve timely completion of the Project.

(2) *Failure to Submit Schedule.* Reliable, up-to-date schedules are essential to efficient and cost-effective administration of the Project and timely completion. If Contractor fails to submit a schedule within the time periods specified in this Section, or submits a schedule to which City has noted exceptions that are not corrected, City may withhold up to five percent from payment(s) otherwise due to Contractor until the exceptions are resolved, the schedule is corrected and resubmitted, and City has accepted the schedule. In addition, Contractor's failure to comply with the schedule requirements in this Section 5.2 will be deemed a material default and a waiver of any claims for Excusable Delay or loss of productivity arising during any period when Contractor is out of compliance, subject only to the limits of Public Contract Code § 7102.

(D) **Recovery Schedule.** If City determines that the Work is more than one week behind schedule, within seven days following written notice of such determination, Contractor must submit a recovery schedule, showing how Contractor intends to perform and complete the Work within the Contract Time, based on actual progress to date.

(E) **Effect of Acceptance.** Contractor and its Subcontractors must perform the Work in accordance with the most current City-accepted schedule unless otherwise directed by City. City's acceptance of a schedule does not operate to extend the time for completion of the Work or any component of the Work, and will not affect City's right to assess liquidated damages for Contractor's unexcused delay in completing the Work within the Contract Time.

(F) **Posting.** Contractor must at all times prominently post a copy of the most current City-accepted progress or recovery schedule in its on-site office.

(G) **Reservation of Rights.** City reserves the right to direct the sequence in which the Work must be performed or to make changes in the sequence of the Work in order to facilitate the performance of work by City or others, or to facilitate City's use of its property. The Contract Time or Contract Price may be adjusted to the extent such changes in sequence actually increase or decrease Contractor's time or cost to perform the Work.

(H) **Authorized Working Days and Times.** Contractor is limited to working Monday through Friday, excluding holidays, during City's normal business hours, except as provided in the Special Conditions or as authorized in writing by City. City reserves the right to charge Contractor for additional costs incurred by City due to Work performed on days or during hours not expressly authorized in the Contract Documents, including

reimbursement of costs incurred for inspection, testing, and construction management services.

5.3 Delay and Extensions of Contract Time.

(A) **Notice of Delay.** If Contractor becomes aware of any actual or potential delay affecting the critical path, Contractor must promptly notify the Engineer in writing, regardless of the nature or cause of the delay, so that City has a reasonable opportunity to mitigate or avoid the delay.

(B) **Excusable Delay.** The Contract Time may be extended if Contractor encounters "Excusable Delay," which is an unavoidable delay in completing the Work within the Contract Time due to causes completely beyond Contractor's control, and which Contractor could not have avoided or mitigated through reasonable care, planning, foresight, or diligence, provided that Contractor is otherwise fully performing its obligations under the Contract Documents. Grounds for Excusable Delay may include fire, natural disasters including earthquake or unusually severe weather, acts of terror or vandalism, epidemic, unforeseeable adverse government actions, unforeseeable actions of third parties, encountering unforeseeable hazardous materials, unforeseeable site conditions, or suspension for convenience under Article 13. The Contract Time will not be extended based on circumstances which will not unavoidably delay completing the Work within the Contract Time based on critical path analysis.

(C) **Weather Delays.** A "Weather Delay Day" is a Working Day during which Contractor and its forces, including Subcontractors, are unable to perform more than 40% of the critical path Work scheduled for that day due to adverse weather conditions which impair the ability to safely or effectively perform the scheduled critical path Work that day. Adverse weather conditions may include rain, saturated soil, and Project site clean-up required due to adverse weather. Determination of what constitutes critical path Work scheduled for that day will be based on the most current, City-approved schedule. Contractor will be entitled to a non-compensable extension of the Contract Time for each Weather Delay Day in excess of the normal Weather Delay Days within a given month as determined by reliable records, including monthly rainfall averages, for the preceding ten years (or as otherwise specified in the Special Conditions or Specifications).

(1) Contractor must fully comply with the applicable procedures in Articles 5 and 6 of the General Conditions regarding requests to modify the Contract Time.

(2) Contractor will not be entitled to an extension of time for a Weather Delay Day to the extent Contractor is responsible for concurrent delay on that day.

(3) Contractor must take reasonable steps to mitigate the consequences of Weather Delay Days, including prudent workforce management and protecting the Work, Project Site, materials, and equipment.

(D) **Non-Excusable Delay.** Delay which Contractor could have avoided or mitigated through reasonable care, planning, foresight, or diligence is "Non-Excusable Delay." Contractor is not entitled to an extension of Contract Time or any compensation for Non-Excusable Delay, or for Excusable Delay that is concurrent with Non-Excusable Delay. Non-Excusable Delay includes delay caused by:

(1) weather conditions which are normal for the location of the Project, as determined by reliable records, including monthly rainfall averages, for the preceding ten years;

- (2) Contractor's failure to order equipment and materials sufficiently in advance of the time needed for completion of the Work within the Contract Time;
- (3) Contractor's failure to provide adequate notification to utility companies or agencies for connections or services necessary for completion of the Work within the Contract Time;
- (4) foreseeable conditions which Contractor could have ascertained from reasonably diligent inspection of the Project site or review of the Contract Documents or other information provided or available to Contractor;
- (5) Contractor's failure, refusal, or financial inability to perform the Work within the Contract Time, including insufficient funds to pay its Subcontractors or suppliers;
- (6) performance or non-performance by Contractor's Subcontractors or suppliers;
- (7) the time required to respond to excessive RFIs (see Section 2.5(G));
- (8) delayed submission of required submittals, or the time required for correction and resubmission of defective submittals;
- (9) time required for repair of, re-testing, or re-inspection of defective Work;
- (10) enforcement of Laws by City, or outside agencies with jurisdiction over the Work; or
- (11) City's exercise or enforcement of any of its rights or Contractor's duties pursuant to the Contract Documents, including correction of defective Work, extra inspections or testing due to non-compliance with Contract requirements, safety compliance, environmental compliance, or rejection and return of defective or deficient submittals.

(E) **Compensable Delay.** Pursuant to Public Contract Code § 7102, in addition to entitlement to an extension of Contract Time, Contractor is entitled to compensation for costs incurred due to delay caused solely by City, when that delay is unreasonable under the circumstances involved and not within the contemplation of the parties ("Compensable Delay"). Contractor is not entitled to an extension of Contract Time or recovery of costs for Compensable Delay that is concurrent with Non-Excusable Delay. Delay due to Weather Delay Days in excess of normal for a given month, as set forth in Section 5.3(C), is not Compensable Delay, and will only entitle Contractor to an extension of time commensurate with the time lost due to such delay.

(F) **Recoverable Costs.** Contractor is not entitled to compensation for Excusable Delay unless it is Compensable Delay, as defined above. Contractor is entitled to recover only the actual, direct, reasonable, and substantiated costs ("Recoverable Costs") for each working day that the Compensable Delay prevents Contractor from proceeding with more than 50% of the critical path Work scheduled for that day, based on the most recent progress schedule accepted by City. Recoverable Costs will not include home office overhead or lost profit.

(G) **Request for Extension of Contract Time or Recoverable Costs.** A request for an extension of Contract Time or any associated Recoverable Costs must be submitted in writing to City within 14 calendar days of the date the delay is first encountered, even if the duration of the delay is not yet known at that time, or any entitlement to the Contract

Time extension or to the Recoverable Costs will be deemed waived. In addition to complying with the requirements of this Article 5, the request must be submitted in compliance with the Change Order request procedures in Article 6 below. Strict compliance with these requirements is necessary to ensure that any delay or consequences of delay may be mitigated as soon as possible, and to facilitate cost-efficient administration of the Project and timely performance of the Work. Any request for an extension of Contract Time or Recoverable Costs that does not strictly comply with all of the requirements of Article 5 and Article 6 will be deemed waived.

(1) *Required Contents.* The request must include a detailed description of the cause(s) of the delay and must also describe the measures that Contractor has taken to mitigate the delay and/or its effects, including efforts to mitigate the cost impact of the delay, such as by workforce management or by a change in sequencing. If the delay is still ongoing at the time the request is submitted, the request should also include Contractor's plan for continued mitigation of the delay or its effects.

(2) *Delay Days and Costs.* The request must specify the number of days of Excusable Delay claimed or provide a realistic estimate if the duration of the delay is not yet known. If Contractor believes it is entitled to Recoverable Costs for Compensable Delay, the request must specify the amount and basis for the Recoverable Costs that are claimed or provide a realistic estimate if the amount is not yet known. Any estimate of delay duration or cost must be updated in writing and submitted with all required supporting documentation as soon as the actual time and cost is known. The maximum extension of Contract Time will be the number of days, if any, by which an Excusable Delay or a Compensable Delay exceeds any concurrent Non-Excusable Delay. Contractor is entitled to an extension of Contract Time, or compensation for Recoverable Costs, only if, and only to the extent that, such delay will unavoidably delay Final Completion.

(3) *Supporting Documentation.* The request must also include any and all supporting documentation necessary to evidence the delay and its actual impacts, including scheduling and cost impacts with a time impact analysis using critical path methodology and demonstrating the unavoidable delay to Final Completion. The time impact analysis must be submitted in a form or format acceptable to City.

(4) *Burden of Proof.* Contractor has the burden of proving that: the delay was an Excusable Delay or Compensable Delay, as defined above; Contractor has fully complied with its scheduling obligations in Section 5.2, Schedule Requirements; Contractor has made reasonable efforts to mitigate the delay and its schedule and cost impacts; the delay will unavoidably result in delaying Final Completion; and any Recoverable Costs claimed by Contractor were actually incurred and were reasonable under the circumstances.

(5) *Legal Compliance.* Nothing in this Section 5.3 is intended to require the waiver, alteration, or limitation of the applicability of Public Contract Code § 7102.

(6) *No Waiver.* Any grant of an extension of Contract Time, or compensation for Recoverable Costs due to Compensable Delay, will not operate as a waiver of City's right to assess liquidated damages for Non-Excusable Delay.

(7) *Dispute Resolution.* In the event of a dispute over entitlement to an extension of Contract Time or compensation for Recoverable Costs, Contractor may not stop Work pending resolution of the dispute, but must continue to comply with its duty to diligently prosecute the performance and timely

completion of the Work. Contractor's sole recourse for an unresolved dispute based on City's rejection of a Change Order request for an extension of Contract Time or compensation for Recoverable Costs is to comply with the dispute resolution provisions set forth in Article 12 below.

5.4 Liquidated Damages. It is expressly understood that if Final Completion is not achieved within the Contract Time, City will suffer damages from the delay that are difficult to determine and accurately specify. Pursuant to Public Contract Code § 7203, if Contractor fails to achieve Final Completion within the Contract Time due to Contractor's Non-Excusable Delay, City will charge Contractor in the amount specified in the Contract for each calendar day that Final Completion is delayed beyond the Contract Time, as liquidated damages and not as a penalty. Any waiver of accrued liquidated damages, in whole or in part, is subject to approval of the City Council or its authorized delegee.

(A) **Liquidated Damages.** Liquidated damages will not be assessed for any Excusable Delay or Compensable Delay, as set forth above.

(B) **Milestones.** Liquidated damages may also be separately assessed for failure to meet milestones specified elsewhere in the Contract Documents.

(C) **Setoff.** City is entitled to deduct the amount of liquidated damages assessed against any payments otherwise due to Contractor, including progress payments, Final Payment, or unreleased retention. If there are insufficient Contract funds remaining to cover the full amount of liquidated damages assessed, City is entitled to recover the balance from Contractor or its performance bond surety.

(D) **Occupancy or Use.** Occupancy or use of the Project in whole or in part prior to Final Completion does not constitute City's acceptance of the Project and will not operate as a waiver of City's right to assess liquidated damages for Contractor's Non-Excusable Delay in achieving Final Completion.

(E) **Other Remedies.** City's right to liquidated damages under this Section applies only to damages arising from Contractor's Non-Excusable Delay or failure to complete the Work within the Contract Time. City retains its right to pursue all other remedies under the Contract for other types of damage, including damage to property or persons, costs or diminution in value from defective materials or workmanship, costs to repair or complete the Work, or other liability caused by Contractor.

Article 6 - Contract Modification

6.1 Contract Modification. Subject to the limited exception set forth in subsection (D) below, any change in the Work or the Contract Documents, including the Contract Price or Contract Time, will not be a valid and binding change to the Contract unless it is formalized in a Change Order, including a "no-cost" Change Order or a unilateral Change Order. Changes in the Work pursuant to this Article 6 will not operate to release, limit, or abridge Contractor's warranty obligations pursuant to Article 11 or any obligations of Contractor's bond sureties.

(A) **City-Directed Changes.** City may direct changes in the scope or sequence of Work or the requirements of the Contract Documents, without invalidating the Contract. Such changes may include Extra Work as set forth in subsection (C) below, or deletion or modification of portions of the Work. Contractor must promptly comply with City-directed changes in the Work in accordance with the original Contract Documents, even if Contractor and City have not yet reached agreement as to adjustments to the Contract Price or Contract Time for the change in the Work or for the Extra Work. Contractor is not

entitled to extra compensation for cost savings resulting from “value engineering” pursuant to Public Contract Code § 7101, except to the extent authorized in advance by City in writing, and subject to any applicable procedural requirements for submitting a proposal for value engineering cost savings.

(B) **Disputes.** In the event of a dispute over entitlement to or the amount of a change in Contract Time or a change in Contract Price related to a City-directed change in the Work, Contractor must perform the Work as directed and may not delay its Work or cease Work pending resolution of the dispute, but must continue to comply with its duty to diligently prosecute the performance and timely completion of the Work, including the Work in dispute. Likewise, in the event that City and Contractor dispute whether a portion or portions of the Work are already required by the Contract Documents or constitute Extra Work, or otherwise dispute the interpretation of any portion(s) of the Contract Documents, Contractor must perform the Work as directed and may not delay its Work or cease Work pending resolution of the dispute, but must continue to comply with its duty to diligently prosecute the performance and timely completion of the Work, including the Work in dispute, as directed by City. If Contractor refuses to perform the Work in dispute, City may, acting in its sole discretion, elect to delete the Work from the Contract and reduce the Contract Price accordingly, and self-perform the Work or direct that the Work be performed by others. Alternatively, City may elect to terminate the Contract for convenience or for cause. Contractor’s sole recourse for an unresolved dispute related to changes in the Work or performance of any Extra Work is to comply with the dispute resolution provisions set forth in Article 12, below.

(C) **Extra Work.** City may direct Contractor to perform Extra Work related to the Project. Contractor must promptly perform any Extra Work as directed or authorized by City in accordance with the original Contract Documents, even if Contractor and City have not yet reached agreement on adjustments to the Contract Price or Contract Time for such Extra Work. If Contractor believes it is necessary to perform Extra Work due to changed conditions, Contractor must promptly notify the Engineer in writing, specifically identifying the Extra Work and the reason(s) the Contractor believes it is Extra Work. This notification requirement does not constitute a Change Order request pursuant to Section 6.2, below. Contractor must maintain detailed daily records that itemize the cost of each element of Extra Work, and sufficiently distinguish the direct cost of the Extra Work from the cost of other Work performed. For each day that Contractor performs Extra Work, or Work that Contractor contends is Extra Work, Contractor must submit no later than the following Working Day, a daily report of the Extra Work performed that day and the related costs, together with copies of certified payroll, invoices, and other documentation substantiating the costs (“Extra Work Report”). The Engineer will make any adjustments to Contractor’s Extra Work Report(s) based on the Engineer’s records of the Work. When an Extra Work Report(s) is agreed on and signed by both City and Contractor, the Extra Work Report(s) will become the basis for payment under a duly authorized and signed Change Order. Failure to submit the required documentation by close of business on the next Working Day is deemed a full and complete waiver for any change in the Contract Price or Contract Time for any Extra Work performed that day.

(D) **Minor Changes and RFIs.** Minor field changes, including RFI replies from City, that do not affect the Contract Price or Contract Time and that are approved by the Engineer acting within his or her scope of authority, do not require a Change Order. By executing an RFI reply from City, Contractor agrees that it will perform the Work as clarified therein, with no change to the Contract Price or Contract Time.

(E) **Remedy for Non-Compliance.** Contractor’s failure to promptly comply with a City-directed change is deemed a material breach of the Contract, and in addition to all other remedies available to it, City may, at its sole discretion, hire another contractor or

use its own forces to complete the disputed Work at Contractor's sole expense, and may deduct the cost from the Contract Price.

6.2 Contractor Change Order Requests. Contractor must submit a request or proposal for a change in the Work, compensation for Extra Work, or a change in the Contract Price or Contract Time as a written Change Order request or proposal.

(A) **Time for Submission.** Any request for a change in the Contract Price or the Contract Time must be submitted in writing to the Engineer within 14 calendar days of the date that Contractor first encounters the circumstances, information or conditions giving rise to the Change Order request, even if the total amount of the requested change in the Contract Price or impact on the Contract Time is not yet known at that time. If City requests that Contractor propose the terms of a Change Order, unless otherwise specified in City's request, Contractor must provide the Engineer with a written proposal for the change in the Contract Price or Contract Time within five working days of receiving City's request, in a form satisfactory to the Engineer.

(B) **Required Contents.** Any Change Order request or proposal submitted by Contractor must include a complete breakdown of actual or estimated costs and credits, and must itemize labor, materials, equipment, taxes, insurance, subcontract amounts, and, if applicable, Extra Work Reports. Any estimated cost must be updated in writing as soon as the actual amount is known.

(C) **Required Documentation.** All claimed costs must be fully documented, and any related request for an extension of time or delay-related costs must be included at that time and in compliance with the requirements of Article 5 of the General Conditions. Upon request, Contractor must permit City to inspect its original and unaltered bidding records, subcontract agreements, subcontract change orders, purchase orders, invoices, or receipts associated with the claimed costs.

(D) **Required Form.** Contractor must use City's form(s) for submitting all Change Order requests or proposals, unless otherwise specified by City.

(E) **Certification.** All Change Order requests must be signed by Contractor and must include the following certification:

"The undersigned Contractor certifies under penalty of perjury that its statements and representations in this Change Order request are true and correct. Contractor warrants that this Change Order request is comprehensive and complete as to the Work or changes referenced herein, and agrees that any known or foreseeable costs, expenses, or time extension requests not included herein, are deemed waived."

6.3 Adjustments to Contract Price. The amount of any increase or decrease in the Contract Price will be determined based on one of the following methods listed below, in the order listed with unit pricing taking precedence over the other methods. Markup applies only to City-authorized time and material Work, and does not apply to any other payments to Contractor. For Work items or components that are deleted in their entirety, Contractor will only be entitled to compensation for those direct, actual, and documented costs (including restocking fees), reasonably incurred before Contractor was notified of the City's intent to delete the Work, with no markup for overhead, profit, or other indirect costs.

(A) **Unit Pricing.** Amounts previously provided by Contractor in the form of unit prices, either in a bid schedule or in a post-award schedule of values pursuant to Section 8.1, Schedule of Values, will apply to determine the price for the affected Work, to the

extent applicable unit prices have been provided for that type of Work. No additional markup for overhead, profit, or other indirect costs will be added to the calculation.

(B) **Lump Sum.** A mutually agreed upon, all-inclusive lump sum price for the affected Work with no additional markup for overhead, profit, or other indirect costs.

(C) **Time and Materials.** On a time and materials basis, if and only to the extent compensation on a time and materials basis is expressly authorized by City in advance of Contractor's performance of the Work and subject to any not-to-exceed limit. Time and materials compensation for increased costs or Extra Work (but not decreased costs or deleted Work) will include allowed markup for overhead, profit, and other indirect costs, calculated as the total of the following sums, the cumulative total of which may not exceed the maximum markup rate of 15%:

(1) All direct labor costs provided by the Contractor, excluding superintendence, project management, or administrative costs, plus 15% markup;

(2) All direct material costs provided by the Contractor, including sales tax, plus 15% markup;

(3) All direct plant and equipment rental costs provided by the Contractor, plus 15% markup;

(4) All direct additional subcontract costs plus 10% markup for Work performed by Subcontractors; and

(5) Increased bond or insurance premium costs computed at 1.5% of the total of the previous four sums.

6.4 Unilateral Change Order. If the parties dispute the terms of a proposed Change Order, including disputes over the amount of compensation or extension of time that Contractor has requested, the value of deleted or changed Work, what constitutes Extra Work, or quantities used, City may elect to issue a unilateral Change Order, directing performance of the Work, and authorizing a change in the Contract Price or Contract Time for the adjustment to compensation or time that the City believes is merited. Contractor's sole recourse to dispute the terms of a unilateral Change Order is to submit a timely Claim pursuant to Article 12, below.

6.5 Non-Compliance Deemed Waiver. Contractor waives its entitlement to any increase in the Contract Price or Contract Time if Contractor fails to fully comply with the provisions of this Article. Contractor will not be paid for unauthorized Extra Work.

Article 7 - General Construction Provisions

7.1 Permits, Fees, Business License, and Taxes.

(A) **Permits, Fees, and City Business License.** Contractor must obtain and pay for all permits, fees, and licenses required to perform the Work, including a City business license. Contractor must cooperate with and provide notifications to all government agencies with jurisdiction over the Project, as may be required. Contractor must provide City with copies of all records of permits and permit applications, payment of required fees, and any licenses required for the Work.

(B) **Taxes.** Contractor must pay for all taxes on labor, material, and equipment, except Federal Excise Tax to the extent that City is exempt from Federal Excise Tax.

7.2 Temporary Facilities. Contractor must provide, at Contractor's sole expense, any and all temporary facilities for the Project, including an onsite staging area for materials and equipment, a field office, sanitary facilities, utilities, storage, scaffolds, barricades, walkways, and any other temporary structure required to safely perform the Work along with any incidental utility services. The location of all temporary facilities must be approved by the City prior to installation. Temporary facilities must be safe and adequate for the intended use and installed and maintained in accordance with Laws and the Contract Documents. Contractor must fence and screen the Project site and, if applicable, any separate Worksites, including the staging area, and its operation must minimize inconvenience to neighboring properties. Additional provisions pertaining to temporary facilities may be included in the Specifications or Special Conditions.

(A) **Utilities.** Contractor must install and maintain the power, water, sewer, and all other utilities required for the Project site, including the piping, wiring, internet and wifi connections, and any related equipment necessary to maintain the temporary facilities.

(B) **Removal and Repair.** Contractor must promptly remove all such temporary facilities when they are no longer needed or upon completion of the Work, whichever comes first. Contractor must promptly repair any damage to City's property or to other property caused by the installation, use, or removal of the temporary facilities, and must promptly restore the property to its original or intended condition.

7.3 Noninterference and Site Management. Contractor must avoid interfering with City's use of its property at or adjacent to the Project site, including use of roadways, entrances, parking areas, walkways, and structures. Contractor must also minimize disruption of access to private property in the Project vicinity. Contractor must coordinate with affected property owners, tenants, and businesses, and maintain some vehicle and pedestrian access to their residences or properties at all times. Temporary access ramps, fencing or other measures must be provided as needed. Before blocking access to a private driveway or parking lot, Contractor must provide effective notice to the affected parties at least 48 hours in advance of the pending closure and allow them to remove vehicles. Private driveways, residences and parking lots must have access to a roadway during non-Work hours.

(A) **Offsite Acquisition.** Unless otherwise provided by City, Contractor must acquire, use, and dispose of, at its sole expense, any Worksites, licenses, easements, and temporary facilities necessary to access and perform the Work.

(B) **Offsite Staging Area and Field Office.** If additional space beyond the Project site is needed, such as for the staging area or the field office, Contractor may need to make arrangements with the nearby property owner(s) to secure the space. Before using or occupying any property owned by a third party, Contractor must provide City with a copy of the necessary license agreement, easement, or other written authorization from the property owner, together with a written release from the property owner holding City harmless from any related liability, in a form acceptable to the City Attorney.

(C) **Traffic Management.** Contractor must provide traffic management and traffic controls as specified in the Contract Documents, as required by Laws, and as otherwise required to ensure public and worker safety, and to avoid interference with public or private operations or the normal flow of vehicular, bicycle, or pedestrian traffic.

7.4 Signs. No signs may be displayed on or about City's property, except signage which is required by Laws or by the Contract Documents, without City's prior written approval as to size, design, and location.

7.5 Project Site and Nearby Property Protections.

(A) **General.** Contractor is responsible at all times, on a 24-hour basis and at its sole cost, for protecting the Work, the Project site, and the materials and equipment to be incorporated into the Work, until the City has accepted the Project, excluding any exceptions to acceptance, if any. Except as specifically authorized by City, Contractor must confine its operations to the area of the Project site indicated in the Plans and Specifications. Contractor is liable for any damage caused by Contractor or its Subcontractors to the Work, City's property, the property of adjacent or nearby property owners and the work or personal property of other contractors working for City, including damage related to Contractor's failure to adequately secure the Work or any Worksite.

(1) Subject to City's approval, Contractor will provide and install safeguards to protect the Work; any Worksite, including the Project site; City's real or personal property and the real or personal property of adjacent or nearby property owners, including plant and tree protections.

(2) City wastewater systems may not be interrupted. If the Work disrupts existing sewer facilities, Contractor must immediately notify City and establish a plan, subject to City's approval, to convey the sewage in closed conduits back into the sanitary sewer system. Sewage must not be permitted to flow in trenches or be covered by backfill.

(3) Contractor must remove with due care, and store at City's request, any objects or material from the Project site that City will salvage or reuse at another location.

(4) If directed by Engineer, Contractor must promptly repair or replace any property damage, as specified by the Engineer. However, acting in its sole discretion, City may elect to have the property damage remedied otherwise, and may deduct the cost to repair or replace the damaged property from payment otherwise due to Contractor.

(5) Contractor will not permit any structure or infrastructure to be loaded in a manner that will damage or endanger the integrity of the structure or infrastructure.

(B) **Securing Project Site.** After completion of Work each day, Contractor must secure the Project site and, to the extent feasible, make the area reasonably accessible to the public unless City approves otherwise. All excess materials and equipment not protected by approved traffic control devices must be relocated to the staging area or demobilized. Trench spoils must be hauled off the Project site daily and open excavations must be protected with steel plates. Contractor and Subcontractor personnel may not occupy or use the Project site for any purpose during non-Work hours, except as may be provided in the Contract Documents or pursuant to prior written authorization from City.

(C) **Unforeseen Conditions.** If Contractor encounters facilities, utilities, or other unknown conditions not shown on or reasonably inferable from the Plans or apparent from inspection of the Project site, Contractor must immediately notify the City and promptly submit a Request for Information to obtain further directions from the Engineer. Contractor must avoid taking any action which could cause damage to the facilities or utilities pending further direction from the Engineer. The Engineer's written response will be final and binding on Contractor. If the Engineer's subsequent direction to Contractor affects Contractor's cost or time to perform the Work, Contractor may submit a Change Order request as set forth in Article 6 above.

(D) **Support; Adjacent Properties.** Contractor must provide, install, and maintain all shoring, bracing, and underpinning necessary to provide support to City's property and adjacent properties and improvements thereon. Contractor must provide notifications to adjacent property owners as may be required by Laws. See also, Section 7.15, Trenching of Five Feet or More.

(E) **Notification of Property Damage.** Contractor must immediately notify the City of damage to any real or personal property resulting from Work on the Project. Contractor must immediately provide a written report to City of any such property damage in excess of \$500 (based on estimated cost to repair or replace) within 24 hours of the occurrence. The written report must include: (1) the location and nature of the damage, and the owner of the property, if known; (2) the name and address of each employee of Contractor or any Subcontractor involved in the damage; (3) a detailed description of the incident, including precise location, time, and names and contact information for known witnesses; and (4) a police or first responder report, if applicable. If Contractor is required to file an accident report with another government agency, Contractor will provide a copy of the report to City.

7.6 Materials and Equipment.

(A) **General.** Unless otherwise specified, all materials and equipment required for the Work must be new, free from defects, and of the best grade for the intended purpose, and furnished in sufficient quantities to ensure the proper and expeditious performance of the Work. Contractor must employ measures to preserve the specified quality and fitness of the materials and equipment. Unless otherwise specified, all materials and equipment required for the Work are deemed to include all components required for complete installation and intended operation and must be installed in accordance with the manufacturer's recommendations or instructions. Contractor is responsible for all shipping, handling, and storage costs associated with the materials and equipment required for the Work. Contractor is responsible for providing security and protecting the Work and all of the required materials, supplies, tools and equipment at Contractor's sole cost until City has formally accepted the Project as set forth in Section 11.1, Final Completion. Contractor will not assign, sell, mortgage, or hypothecate any materials or equipment for the Project, or remove any materials or equipment that have been installed or delivered.

(B) **City-Provided.** If the Work includes installation of materials or equipment to be provided by City, Contractor is solely responsible for the proper examination, handling, storage, and installation in accordance with the Contract Documents. Contractor must notify City of any defects discovered in City-provided materials or equipment, sufficiently in advance of scheduled use or installation to afford adequate time to procure replacement materials or equipment as needed. Contractor is solely responsible for any loss of or damage to such items which occurs while the items are in Contractor's custody and control, the cost of which may be offset from the Contract Price and deducted from any payment(s) due to Contractor.

(C) **Intellectual Property Rights.** Contractor must, at its sole expense, obtain any authorization or license required for use of patented or copyright-protected materials, equipment, devices, or processes that are incorporated into the Work. Contractor's indemnity obligations in Article 4 apply to any claimed violation of intellectual property rights.

7.7 Substitutions.

(A) **"Or Equal."** Any Specification designating a material, product, or thing (collectively, "item") or service by specific brand or trade name, followed by the words "or

equal," is intended only to indicate the quality and type of item or service desired, and Contractor may request use of any equal item or service. Unless otherwise stated in the Specifications, any reference to a specific brand or trade name for an item or service that is used solely for the purpose of describing the type of item or service desired, will be deemed to be followed by the words "or equal." A substitution will only be approved if it is a true "equal" item or service in every aspect of design, function, and quality, as determined by City, including dimensions, weight, maintenance requirements, durability, fit with other elements, and schedule impacts.

(B) **Request for Substitution.** A post-award request for substitution of an item or service must be submitted in writing to the Engineer for approval in advance, within the applicable time period provided in the Contract Documents. If no time period is specified, the substitution request may be submitted any time within 35 days after the date of award of the Contract, or sufficiently in advance of the time needed to avoid delay of the Work, whichever is earlier.

(C) **Substantiation.** Any available data substantiating the proposed substitute as an equal item or service must be submitted with the written request for substitution. Contractor's failure to timely provide all necessary substantiation, including any required test results as soon as they are available, is grounds for rejection of the proposed substitution, without further review.

(D) **Burden of Proving Equality.** Contractor has the burden of proving the equality of the proposed substitution at Contractor's sole cost. City has sole discretion to determine whether a proposed substitution is equal, and City's determination is final.

(E) **Approval or Rejection.** If the proposed substitution is approved, Contractor is solely responsible for any additional costs or time associated with the substituted item or service. If the proposed substitution is rejected, Contractor must, without delay, install the item or use the service as specified by City.

(F) **Contractor's Obligations.** City's approval of a proposed substitution will not relieve Contractor from any of its obligations under the Contract Documents. In the event Contractor makes an unauthorized substitution, Contractor will be solely responsible for all resulting cost impacts, including the cost of removal and replacement and the impact to other design elements.

7.8 Testing and Inspection.

(A) **General.** All materials, equipment, and workmanship used in the Work are subject to inspection and testing by City at all times and at all locations during construction and/or fabrication, including at any Worksite, shops, and yards. All manufacturers' application or installation instructions must be provided to the Inspector at least ten days prior to the first such application or installation. Contractor must, at all times, make the Work available for testing or inspection. Neither City's inspection or testing of Work, nor its failure to do so, operate to waive or limit Contractor's duty to complete the Work in accordance with the Contract Documents.

(B) **Scheduling and Notification.** Contractor must cooperate with City in coordinating the inspections and testing. Contractor must submit samples of materials, at Contractor's expense, and schedule all tests required by the Contract Documents in time to avoid any delay to the progress of the Work. Contractor must notify the Engineer no later than noon of the Working Day before any inspection or testing and must provide timely notice to the other necessary parties as specified in the Contract Documents. If Contractor schedules an inspection or test beyond regular Work hours, or on a Saturday, Sunday, or recognized City holiday, Contractor must notify the Engineer at least two

Working Days in advance for approval. If approved, Contractor must reimburse City for the cost of the overtime inspection or testing. Such costs, including the City's hourly costs for required personnel, may be deducted from payments otherwise due to Contractor.

(C) **Responsibility for Costs.** City will bear the initial cost of inspection and testing to be performed by independent consultants retained by City, subject to the following exceptions:

- (1) Contractor will be responsible for the costs of any subsequent inspections or tests which are required to substantiate compliance with the Contract Documents, and any associated remediation costs.
- (2) Contractor will be responsible for inspection costs, at City's hourly rates, for inspection time lost because the Work is not ready, or Contractor fails to appear for a scheduled inspection.
- (3) If any portion of the Work that is subject to inspection or testing is covered or concealed by Contractor prior to the inspection or testing, Contractor will bear the cost of making that portion of the Work available for the inspection or testing required by the Contract Documents, and any associated repair or remediation costs.
- (4) Contractor is responsible for properly shoring all compaction test sites deeper than five feet below grade, as required under Section 7.15 below.
- (5) Any Work or material that is defective or fails to comply with the requirements of the Contract Documents must be promptly repaired, removed, replaced, or corrected by Contractor, at Contractor's sole expense, even if that Work or material was previously inspected or included in a progress payment.

(D) **Contractor's Obligations.** Contractor is solely responsible for any delay occasioned by remediation of defective or noncompliant Work or material. Inspection or testing of the Work does not in any way relieve Contractor of its obligations to perform the Work as specified. Any Work done without the inspection(s) or testing required by the Contract Documents will be subject to rejection by City.

(E) **Distant Locations.** If required off-site testing or inspection must be conducted at a location more than 100 miles from the Project site, Contractor is solely responsible for the additional travel costs required for testing and/or inspection at such locations.

(F) **Final Inspection.** The provisions of this Section 7.8 also apply to final inspection under Article 11, Completion and Warranty Provisions.

7.9 Project Site Conditions and Maintenance. Contractor must at all times, on a 24-hour basis and at its sole cost, maintain the Project site and staging and storage areas in clean, neat, and sanitary condition and in compliance with all Laws pertaining to safety, air quality, and dust control. Adequate toilets must be provided, and properly maintained and serviced for all workers on the Project site, located in a suitably secluded area, subject to City's prior approval. Contractor must also, on a daily basis and at its sole cost, remove and properly dispose of the debris and waste materials from the Project site.

(A) **Air Emissions Control.** Contractor must not discharge smoke or other air contaminants into the atmosphere in violation of any Laws. Contractor must comply with all Laws, including the California Air Resources Board's In-Use Off-Road Diesel-Fueled Fleets Regulation (13 CCR § 2449 et seq.).

(B) **Dust and Debris.** Contractor must minimize and confine dust and debris resulting from the Work. Contractor must abate dust nuisance by cleaning, sweeping, and immediately sprinkling with water excavated areas of dirt or other materials prone to cause dust, and within one hour after the Engineer notifies Contractor that an airborne nuisance exists. The Engineer may direct that Contractor provide an approved water-spraying truck for this purpose. If water is used for dust control, Contractor will only use the minimum necessary. Contractor must take all necessary steps to keep waste water out of streets, gutters, or storm drains. See Section 7.19, Environmental Control. If City determines that the dust control is not adequate, City may have the work done by others and deduct the cost from the Contract Price. Contractor will immediately remove any excess excavated material from the Project site and any dirt deposited on public streets.

(C) **Clean up.** Before discontinuing Work in an area, Contractor must clean the area and remove all debris and waste along with the construction equipment, tools, machinery, and surplus materials.

(1) Except as otherwise specified, all excess Project materials, and the materials removed from existing improvements on the Project site with no salvage value or intended reuse by City, will be Contractor's property.

(2) Hauling trucks and other vehicles leaving the Project site must be cleaned of exterior mud or dirt before traveling on City streets. Materials and loose debris must be delivered and loaded to prevent dropping materials or debris. Contractor must immediately remove spillage from hauling on any publicly traveled way. Streets affected by Work on the Project must be kept clean by street sweeping.

(D) **Disposal.** Contractor must dispose of all Project debris and waste materials in a safe and legal manner. Contractor may not burn or bury waste materials on the Project site. Contractor will not allow any dirt, refuse, excavated material, surplus concrete or mortar, or any associated washings, to be disposed of onto streets, into manholes or into the storm drain system.

(E) **Completion.** At the completion of the Work, Contractor must remove from the Project site all of its equipment, tools, surplus materials, waste materials and debris, presenting a clean and neat appearance. Before demobilizing from the Project site, Contractor must ensure that all surfaces are cleaned, sealed, waxed, or finished as applicable, and that all marks, stains, paint splatters, and the like have been properly removed from the completed Work and the surrounding areas. Contractor must ensure that all parts of the construction are properly joined with the previously existing and adjacent improvements and conditions. Contractor must provide all cutting, fitting and patching needed to accomplish that requirement. Contractor must also repair or replace all existing improvements that are damaged or removed during the Work, both on and off the Project site, including curbs, sidewalks, driveways, fences, signs, landscaping, utilities, street surfaces and structures. Repairs and replacements must be at least equal to the previously existing improvements, and the condition, finish and dimensions must match the previously existing improvements. Contractor must restore to original condition all property or items that are not designated for alteration under the Contract Documents and leave each Worksite clean and ready for occupancy or use by City.

(F) **Non-Compliance.** If Contractor fails to comply with its maintenance and cleanup obligations or any City clean up order, City may, acting in its sole discretion, elect to suspend the Work until the condition(s) is corrected with no increase in the Contract Time or Contract Price, or undertake appropriate cleanup measures without further notice and deduct the cost from any amounts due or to become due to Contractor.

7.10 Instructions and Manuals. Contractor must provide to City three copies each of all instructions and manuals required by the Contract Documents, unless otherwise specified. These must be complete as to drawings, details, parts lists, performance data, and other information that may be required for City to easily maintain and service the materials and equipment installed for this Project.

(A) **Submittal Requirements.** The instructions and manuals, along with any required guarantees, must be delivered to City for review prior to requesting final inspection pursuant to Section 11.1(A), unless otherwise specified.

(B) **Training.** Contractor or its Subcontractors must train City's personnel in the operation and maintenance of any complex equipment or systems as a condition precedent to Final Completion, if required in the Contract Documents.

7.11 As-built Drawings. Contractor and its Subcontractors must prepare and maintain at the Project site a detailed, complete and accurate as-built set of the Plans which will be used solely for the purpose of recording changes made in any portion of the original Plans in order to create accurate record drawings at the end of the Project.

(A) **Duty to Update.** The as-built drawings must be updated as changes occur, on a daily basis if necessary. City may withhold the estimated cost for City to have the as-built drawings prepared from payments otherwise due to Contractor, until the as-built drawings are brought up to date to the satisfaction of City. Actual locations to scale must be identified on the as-built drawings for all runs of mechanical and electrical work, including all site utilities installed underground, in walls, floors, or otherwise concealed. Deviations from the original Plans must be shown in detail. The exact location of all main runs, whether piping, conduit, ductwork or drain lines, must be shown by dimension and elevation. The location of all buried pipelines, appurtenances, or other improvements must be represented by coordinates and by the horizontal distance from visible above-ground improvements.

(B) **Final Completion.** Contractor must verify that all changes in the Work are depicted in the as-built drawings and must deliver the complete set of as-built drawings to the Engineer for review and acceptance as a condition precedent to Final Completion and Final Payment.

7.12 Existing Utilities.

(A) **General.** The Work may be performed in developed, urban areas with existing utilities, both above and below ground, including utilities identified in the Contract Documents or in other informational documents or records. Contractor must take due care to locate identified or reasonably identifiable utilities before proceeding with trenching, excavation, or any other activity that could damage or disrupt existing utilities. This may include excavation with small equipment, potholing, or hand excavation, and, if practical, using white paint or other suitable markings to delineate the area to be excavated. Except as otherwise provided herein, Contractor will be responsible for costs resulting from damage to identified or reasonably identifiable utilities due to Contractor's negligence or failure to comply with the Contract Documents, including the requirements in this Article 7.

(B) **Unidentified Utilities.** Pursuant to Government Code § 4215, if, during the performance of the Work, Contractor discovers utility facilities not identified by City in the Contract Documents, Contractor must immediately provide written notice to City and the utility. City assumes responsibility for the timely removal, relocation, or protection of existing main or trunkline utility facilities located on the Project site if those utilities are not identified in the Contract Documents. Contractor will be compensated in accordance with

the provisions of the Contract Documents for the costs of locating, repairing damage not due to Contractor's failure to exercise reasonable care, and removing or relocating utility facilities not indicated in the Plans or Specifications with reasonable accuracy, and for equipment on the Project necessarily idled during such work. Contractor will not be assessed liquidated damages for delay in completion of the Work, to the extent the delay was caused by City's failure to provide for removal or relocation of the utility facilities.

7.13 Notice of Excavation. Contractor must comply with all applicable requirements in Government Code § 4216 et seq., which are incorporated by reference herein.

7.14 Trenching and Excavations of Four Feet or More. As required by Public Contract Code § 7104, if the Work includes digging trenches or other excavations that extend deeper than four feet below the surface, the provisions in this Section apply to the Work and the Project.

(A) **Duty to Notify.** Contractor must promptly, and before the following conditions are disturbed, provide written notice to City if Contractor finds any of the following conditions:

(1) Material that Contractor believes may be a hazardous waste, as defined in § 25117 of the Health and Safety Code, that is required to be removed to a Class I, Class II, or Class III disposal site in accordance with the provisions of existing Laws;

(2) Subsurface or latent physical conditions at the Project site differing from those indicated by information about the Project site made available to bidders prior to the deadline for submitting bids; or

(3) Unknown physical conditions at the Project site of any unusual nature, materially different from those ordinarily encountered and generally recognized as inherent in work of the character required by the Contract Documents.

(B) **City Investigation.** City will promptly investigate the conditions and if City finds that the conditions materially differ from those indicated, apparent, or reasonably inferred from information about the Project site made available to bidders, or involve hazardous waste, and cause a decrease or increase in Contractor's cost of, or the time required for, performance of any part of the Work, City will issue a Change Order.

(C) **Disputes.** In the event that a dispute arises between City and Contractor regarding any of the conditions specified in subsection (B) above, or the terms of a Change Order issued by City, Contractor will not be excused from completing the Work within the Contract Time, but must proceed with all Work to be performed under the Contract. Contractor will retain any and all rights provided either by the Contract or by Laws which pertain to the resolution of disputes between Contractor and City.

7.15 Trenching of Five Feet or More. As required by Labor Code § 6705, if the Contract Price exceeds \$25,000 and the Work includes the excavation of any trench or trenches of five feet or more in depth, a detailed plan must be submitted to City for acceptance in advance of the excavation. The detailed plan must show the design of shoring, bracing, sloping, or other provisions to be made for worker protection from the hazard of caving ground during the excavation. If the plan varies from the shoring system standards, it must be prepared by a California registered civil or structural engineer. Use of a shoring, sloping, or protective system less effective than that required by the Construction Safety Orders is prohibited.

7.16 New Utility Connections. Except as otherwise specified, City will pay connection charges and meter costs for new permanent utilities required by the Contract Documents, if any. Contractor must notify City sufficiently in advance of the time needed to request service from each utility provider so that connections and services are initiated in accordance with the Project schedule.

7.17 Lines and Grades. Contractor is required to use any benchmark provided by the Engineer. Unless otherwise specified in the Contract Documents, Contractor must provide all lines and grades required to execute the Work. Contractor must also provide, preserve, and replace if necessary, all construction stakes required for the Project. All stakes or marks must be set by a California licensed surveyor or a California registered civil engineer. Contractor must notify the Engineer of any discrepancies found between Contractor's staking and grading and information provided by the Contract Documents. Upon completion, all Work must conform to the lines, elevations, and grades shown in the Plans, including any changes directed by a Change Order.

7.18 Historic or Archeological Items.

(A) **Contractor's Obligations.** Contractor must ensure that all persons performing Work at the Project site are required to immediately notify the Project Manager, upon discovery of any potential historic or archeological items, including historic or prehistoric ruins, a burial ground, archaeological or vertebrate paleontological site, including fossilized footprints or other archeological, paleontological or historical feature on the Project site (collectively, "Historic or Archeological Items").

(B) **Discovery; Cessation of Work.** Upon discovery of any potential Historic or Archeological Items, Work must be stopped within an 85-foot radius of the find and may not resume until authorized in writing by City. If required by City, Contractor must assist in protecting or recovering the Historic or Archeological Items, with any such assistance to be compensated as Extra Work on a time and materials basis under Article 6, Contract Modification. At City's discretion, a suspension of Work required due to discovery of Historic or Archeological Items may be treated as Excusable Delay pursuant to Article 5, or as a suspension for convenience under Article 13.

7.19 Environmental Control. Contractor must not pollute any drainage course or its tributary inlets with fuels, oils, bitumens, acids, insecticides, herbicides or other harmful materials. Contractor must prevent the release of any hazardous material or hazardous waste into the soil or groundwater, and prevent the unlawful discharge of pollutants into City's storm drain system and watercourses as required below. Contractor and its Subcontractors must at all times in the performance of the Work comply with all Laws concerning pollution of waterways.

(A) **Stormwater Permit.** Contractor must comply with all applicable conditions of the State Water Resources Control Board National Pollutant Discharge Elimination System General Permit for Waste Discharge Requirements for Discharges of Stormwater Runoff Associated with Construction Activity ("Stormwater Permit").

(B) **Contractor's Obligations.** If required for the Work, a copy of the Stormwater Permit is on file in City's principal administrative offices, and Contractor must comply with it without adjustment of the Contract Price or the Contract Time. Contractor must timely and completely submit required reports and monitoring information required by the conditions of the Stormwater Permit. Contractor also must comply with all other Laws governing discharge of stormwater, including applicable municipal stormwater management programs.

- 7.20 Noise Control.** Contractor must comply with all applicable noise control Laws. Noise control requirements apply to all equipment used for the Work or related to the Work, including trucks, transit mixers or transient equipment that may or may not be owned by Contractor.
- 7.21 Mined Materials.** Pursuant to Public Contract Code § 20676, Contractor will not purchase any sand, gravel, or other minerals for the Work from an operation subject to the Surface Mining and Reclamation Act of 1975 (Public Resources Code § 2710 et seq.) unless the Contractor certifies, under penalty of perjury, that the minerals are from a mining operation included on the AB 3098 List, which may be accessed online at: <https://www.conservation.ca.gov/smgb/Pages/AB-3098-List.aspx>.

Article 8 - Payment

- 8.1 Schedule of Values.** Prior to submitting its first application for payment, Contractor must prepare and submit to the Project Manager a schedule of values apportioned to the various divisions and phases of the Work, including mobilization and demobilization. If a Bid Schedule was submitted with Contractor's bid, the amounts in the schedule of values must be consistent with the Bid Schedule. Each line item contained in the schedule of values must be assigned a value such that the total of all items equals the Contract Price. The items must be sufficiently detailed to enable accurate evaluation of the percentage of completion claimed in each application for payment, and the assigned value consistent with any itemized or unit pricing submitted with Contractor's bid.

(A) **Measurements for Unit Price Work.** Materials and items of Work to be paid for on the basis of unit pricing will be measured according to the methods specified in the Contract Documents.

(B) **Deleted or Reduced Work.** Contractor will not be compensated for Work that City has deleted or reduced in scope, except for any labor, material, or equipment costs for such Work that Contractor reasonably incurred before Contractor learned that the Work could be deleted or reduced. Contractor will only be compensated for those actual, direct and documented costs incurred, and will not be entitled to any mark up for overhead or lost profits.

- 8.2 Progress Payments.** Following the last day of each month, or as otherwise required by the Special Conditions or Specifications, Contractor will submit to the Project Manager a monthly application for payment for Work performed during the preceding month based on the estimated value of the Work performed during that preceding month.

(A) **Application for Payment.** Each application for payment must be itemized to include labor, materials, and equipment incorporated into the Work, and materials and equipment delivered to the Project site, as well as authorized and approved Change Orders. Each payment application must be supported by the unit prices submitted with Contractor's Bid Schedule and/or schedule of values and any other substantiating data required by the Contract Documents.

(B) **Payment of Undisputed Amounts.** City will pay the undisputed amount due within 30 days after Contractor has submitted a complete and accurate payment application, subject to Public Contract Code § 20104.50. City will deduct a percentage from each progress payment as retention, as set forth in Section 8.5, below, and may deduct or withhold additional amounts as set forth in Section 8.3, below.

- 8.3 Adjustment of Payment Application.** City may adjust or reject the amount requested in a payment application, including application for Final Payment, in whole or in part, if the

amount requested is disputed or unsubstantiated. Contractor will be notified in writing of the basis for the modification to the amount requested. City may also deduct or withhold from payment otherwise due based upon any of the circumstances and amounts listed below. Sums withheld from payment otherwise due will be released when the basis for that withholding has been remedied and no longer exists.

- (A) For Contractor's unexcused failure to perform the Work as required by the Contract Documents, including correction or completion of punch list items, City may withhold or deduct an amount based on the City's estimated cost to correct or complete the Work.
- (B) For loss or damage caused by Contractor or its Subcontractors arising out of or relating to performance of the Work or any failure to protect the Project site, City may deduct an amount based on the estimated cost to repair or replace.
- (C) For Contractor's failure to pay its Subcontractors and suppliers when payment is due, City may withhold an amount equal to the total of past due payments and may opt to pay that amount separately via joint check pursuant to Section 8.6(B), Joint Checks.
- (D) For Contractor's failure to timely correct rejected, nonconforming, or defective Work, City may withhold or deduct an amount based on the City's estimated cost to correct or complete the Work.
- (E) For any unreleased stop notice, City may withhold 125% of the amount claimed.
- (F) For Contractor's failure to submit any required schedule or schedule update in the manner specified or within the time specified in the Contract Documents, City may withhold an amount equal to five percent of the total amount requested until Contractor complies with its schedule submittal obligations.
- (G) For Contractor's failure to maintain or submit as-built documents in the manner specified or within the time specified in the Contract Documents, City may withhold or deduct an amount based on the City's cost to prepare the as-builts.
- (H) For Work performed without Shop Drawings that have been accepted by City, when accepted Shop Drawings are required before proceeding with the Work, City may deduct an amount based on the estimated cost to correct unsatisfactory Work or diminution in value.
- (I) For fines, payments, or penalties assessed under the Labor Code, City may deduct from payments due to Contractor as required by Laws and as directed by the Division of Labor Standards Enforcement.
- (J) For any other fines, payments, or penalties assessed against the City relating to Contractor's acts or omissions, including violations of Laws, City may withhold or deduct such amounts from payment otherwise due to Contractor.
- (K) For any other costs or charges that may be withheld or deducted from payments to Contractor, as provided in the Contract Documents, including liquidated damages, City may withhold or deduct such amounts from payment otherwise due to Contractor.

8.4 Early Occupancy. Neither City's payment of progress payments nor its partial or full use or occupancy of the Project constitutes acceptance of any part of the Work.

8.5 Retention. City will retain five percent of the full amount due on each progress payment (i.e., the amount due before any withholding or deductions pursuant to Section 8.3,

Adjustment of Payment Application), or the percentage stated in the Notice Inviting Bids, whichever is greater, as retention to ensure full and satisfactory performance of the Work. Contractor is not entitled to any reduction in the rate of withholding at any time, nor to release of any retention before 35 days following City's recordation of the Notice of Completion, subject to the terms of Public Contract Code § 7107.

(A) **Substitution of Securities.** As provided by Public Contract Code § 22300, Contractor may request in writing that it be allowed, at its sole expense, to substitute securities for the retention withheld by City. Any escrow agreement entered into pursuant to this provision must fully comply with Public Contract Code § 22300 and will be subject to approval as to form by City's legal counsel. If City exercises its right to draw upon such securities in the event of default pursuant to section (7) of the statutory Escrow Agreement for Security Deposits in Lieu of Retention, pursuant to subdivision (g) of Public Contract Code § 22300 ("Escrow Agreement"), and if Contractor disputes that it is in default, its sole remedy is to comply with the dispute resolution procedures in Article 12 and the provisions therein. It is agreed that for purposes of this paragraph, an event of default includes City's rights pursuant to these Contract Documents to withhold or deduct sums from retention, including withholding or deduction for liquidated damages, incomplete or defective Work, stop payment notices, or backcharges. It is further agreed that if any individual authorized to give or receive written notice on behalf of a party pursuant to section (10) of the Escrow Agreement are unavailable to give or receive notice on behalf of that party due to separation from employment, retirement, death, or other circumstances, the successor or delegee of the named individual is deemed to be the individual authorized to give or receive notice pursuant to section (10) of the Escrow Agreement.

(B) **Release of Undisputed Retention.** All undisputed retention, less any amounts that may be assessed as liquidated damages, retained for stop notices, or otherwise withheld pursuant to Section 8.3, Adjustment of Payment Application, will be released as Final Payment to Contractor no sooner than 35 days following recordation of the notice of completion, and no later than 60 days following acceptance of the Project by City's governing body or authorized designee pursuant to Section 11.1(C), Acceptance, or, if the Project has not been accepted, no later than 60 days after the Project is otherwise considered complete pursuant to Public Contract Code § 7107(c).

8.6 Payment to Subcontractors and Suppliers. Each month, Contractor must promptly pay each Subcontractor and supplier the value of the portion of labor, materials, and equipment incorporated into the Work or delivered to the Project site by the Subcontractor or supplier during the preceding month. Such payments must be made in accordance with the requirements of Laws pertaining to such payments, and those of the Contract Documents and applicable subcontract or supplier contract.

(A) **Withholding for Stop Notice.** Pursuant to Civil Code § 9358, City will withhold 125% of the amount claimed by an unreleased stop notice, a portion of which may be retained by City for the costs incurred in handling the stop notice claim, including attorneys' fees and costs, as authorized by law.

(B) **Joint Checks.** City reserves the right, acting in its sole discretion, to issue joint checks made payable to Contractor and a Subcontractor or supplier, if City determines this is necessary to ensure fair and timely payment for a Subcontractor or supplier who has provided services or goods for the Project. As a condition to release of payment by a joint check, the joint check payees may be required to execute a joint check agreement in a form provided or approved by the City Attorney's Office. The joint check payees will be jointly and severally responsible for the allocation and disbursement of funds paid by joint check. Payment by joint check will not be construed to create a contractual relationship

between City and a Subcontractor or supplier of any tier beyond the scope of the joint check agreement.

- 8.7 Final Payment.** Contractor's application for Final Payment must comply with the requirements for submitting an application for a progress payment as stated in Section 8.2, above. Corrections to previous progress payments, including adjustments to estimated quantities for unit priced items, may be included in the Final Payment. If Contractor fails to submit a timely application for Final Payment, City reserves the right to unilaterally process and issue Final Payment without an application from Contractor in order to close out the Project. For the purposes of determining the deadline for Claim submission pursuant to Article 12, the date of Final Payment is deemed to be the date that City acts to release undisputed retention as final payment to Contractor, or otherwise provides written notice to Contractor of Final Payment or that no undisputed funds remain available for Final Payment due to offsetting withholdings or deductions pursuant to Section 8.3, Adjustment of Payment Application. If the amount due from Contractor to City exceeds the amount of Final Payment, City retains the right to recover the balance from Contractor or its sureties.
- 8.8 Release of Claims.** City may, at any time, require that payment of the undisputed portion of any progress payment or Final Payment be contingent upon Contractor furnishing City with a written waiver and release of all claims against City arising from or related to the portion of Work covered by those undisputed amounts subject to the limitations of Public Contract Code § 7100. Any disputed amounts may be specifically excluded from the release.
- 8.9 Warranty of Title.** Contractor warrants that title to all work, materials, or equipment incorporated into the Work and included in a request for payment will pass over to City free of any claims, liens, or encumbrances upon payment to Contractor.

Article 9 - Labor Provisions

- 9.1 Discrimination Prohibited.** Discrimination against any prospective or present employee engaged in the Work on grounds of race, color, ancestry, national origin, ethnicity, religion, sex, sexual orientation, age, disability, or marital status is strictly prohibited. Contractor and its Subcontractors are required to comply with all applicable Laws prohibiting discrimination, including the California Fair Employment and Housing Act (Govt. Code § 12900 et seq.), Government Code § 11135, and Labor Code §§ 1735, 1777.5, 1777.6, and 3077.5.
- 9.2 Labor Code Requirements.**
- (A) **Eight Hour Day.** Pursuant to Labor Code § 1810, eight hours of labor constitute a legal day's work under this Contract.
- (B) **Penalty.** Pursuant to Labor Code § 1813, Contractor will forfeit to City as a penalty, the sum of \$25.00 for each day during which a worker employed by Contractor or any Subcontractor is required or permitted to work more than eight hours in any one calendar day or more than 40 hours per calendar week, except if such workers are paid overtime under Labor Code § 1815.
- (C) **Apprentices.** Contractor is responsible for compliance with the requirements governing employment and payment of apprentices, as set forth in Labor Code § 1777.5, which is fully incorporated by reference.

(D) **Notices.** Pursuant to Labor Code § 1771.4, Contractor is required to post all job site notices prescribed by Laws.

9.3 Prevailing Wages. Each worker performing Work under this Contract that is covered under Labor Code §§ 1720, 1720.3, or 1720.9, including cleanup at the Project site, must be paid at a rate not less than the prevailing wage as defined in §§ 1771 and 1774 of the Labor Code. The prevailing wage rates are on file with the City and available online at <http://www.dir.ca.gov/dlsr>. Contractor must post a copy of the applicable prevailing rates at the Project site.

(A) **Penalties.** Pursuant to Labor Code § 1775, Contractor and any Subcontractor will forfeit to City as a penalty up to \$200.00 for each calendar day, or portion thereof, for each worker paid less than the applicable prevailing wage rate. Contractor must also pay each worker the difference between the applicable prevailing wage rate and the amount actually paid to that worker.

(B) **Federal Requirements.** If this Project is subject to federal prevailing wage requirements in addition to California prevailing wage requirements, Contractor and its Subcontractors are required to pay the higher of the currently applicable state or federal prevailing wage rates.

9.4 Payroll Records. Contractor must comply with the provisions of Labor Code §§ 1771.4, 1776, and 1812 and all implementing regulations, which are fully incorporated by this reference, including requirements for monthly electronic submission of payroll records to the DIR.

(A) **Contractor and Subcontractor Obligations.** Contractor and each Subcontractor must keep accurate payroll records, showing the name, address, social security number, work classification, straight time and overtime hours worked each day and week, and the actual per diem wages paid to each journeyman, apprentice, worker, or other employee employed in connection with the Work. Each payroll record must contain or be verified by a written declaration that it is made under penalty of perjury, stating both of the following:

(1) The information contained in the payroll record is true and correct; and

(2) Contractor or the Subcontractor has complied with the requirements of Labor Code §§ 1771, 1811, and 1815 for any Work performed by its employees on the Project.

(B) **Certified Record.** A certified copy of an employee's payroll record must be made available for inspection or furnished to the employee or his or her authorized representative on request, to City, to the Division of Labor Standards Enforcement, to the Division of Apprenticeship Standards of the DIR, and as further required by the Labor Code.

(C) **Enforcement.** Upon notice of noncompliance with Labor Code § 1776, Contractor or Subcontractor has ten days in which to comply with the requirements of this section. If Contractor or Subcontractor fails to do so within the ten-day period, Contractor or Subcontractor will forfeit a penalty of \$100.00 per day, or portion thereof, for each worker for whom compliance is required, until strict compliance is achieved. Upon request by the Division of Apprenticeship Standards, or the Division of Labor Standards Enforcement, these penalties will be withheld from payments then due to Contractor.

9.5 Labor Compliance. Pursuant to Labor Code § 1771.4, the Contract for this Project is subject to compliance monitoring and enforcement by the DIR.

Article 10 - Safety Provisions

10.1 Safety Precautions and Programs. Contractor and its Subcontractors are fully responsible for safety precautions and programs, and for the safety of persons and property in the performance of the Work. Contractor and its Subcontractors must at all times comply with all applicable health and safety Laws and seek to avoid injury, loss, or damage to persons or property by taking reasonable steps to protect its employees and other persons at any Worksite, materials and equipment stored on or off site, and property at or adjacent to any Worksite.

(A) **Reporting Requirements.** Contractor must immediately notify the City of any death, serious injury or illness resulting from Work on the Project. Contractor must immediately provide a written report to City of each recordable accident or injury occurring at any Worksite within 24 hours of the occurrence. The written report must include: (1) the name and address of the injured or deceased person; (2) the name and address of each employee of Contractor or of any Subcontractor involved in the incident; (3) a detailed description of the incident, including precise location, time, and names and contact information for known witnesses; and (4) a police or first responder report, if applicable. If Contractor is required to file an accident report with a government agency, Contractor will provide a copy of the report to City.

(B) **Legal Compliance.** Contractor's safety program must comply with the applicable legal and regulatory requirements. Contractor must provide City with copies of all notices required by Laws.

(C) **Contractor's Obligations.** Any damage or loss caused by Contractor arising from the Work which is not insured under property insurance must be promptly remedied by Contractor.

(D) **Remedies.** If City determines, in its sole discretion, that any part of the Work or Project site is unsafe, City may, without assuming responsibility for Contractor's safety program, require Contractor or its Subcontractor to cease performance of the Work or to take corrective measures to City's satisfaction. If Contractor fails to promptly take the required corrective measures, City may perform them and deduct the cost from the Contract Price. Contractor agrees it is not entitled to submit a Claim for damages, for an increase in Contract Price, or for a change in Contract Time based on Contractor's compliance with City's request for corrective measures pursuant to this provision.

10.2 Hazardous Materials. Unless otherwise specified in the Contract Documents, this Contract does not include the removal, handling, or disturbance of any asbestos or other Hazardous Materials. If Contractor encounters materials on the Project site that Contractor reasonably believes to be asbestos or other Hazardous Materials, and the asbestos or other Hazardous Materials have not been rendered harmless, Contractor may continue Work in unaffected areas reasonably believed to be safe, but must immediately cease work on the area affected and report the condition to City. No asbestos, asbestos-containing products or other Hazardous Materials may be used in performance of the Work.

10.3 Material Safety. Contractor is solely responsible for complying with § 5194 of Title 8 of the California Code of Regulations, including by providing information to Contractor's employees about any hazardous chemicals to which they may be exposed in the course of the Work. A hazard communication program and other forms of warning and training about such exposure must be used. Contractor must also maintain Safety Data Sheets ("SDS") at the Project site, as required by Laws, for materials or substances used or

consumed in the performance of the Work. The SDS will be accessible and available to Contractor's employees, Subcontractors, and City.

(A) **Contractor Obligations.** Contractor is solely responsible for the proper delivery, handling, use, storage, removal, and disposal of all materials brought to the Project site and/or used in the performance of the Work. Contractor must notify the Engineer if a specified product or material cannot be used safely.

(B) **Labeling.** Contractor must ensure proper labeling on any material brought onto the Project site so that any persons working with or in the vicinity of the material may be informed as to the identity of the material, any potential hazards, and requirements for proper handling, protections, and disposal.

10.4 Hazardous Condition. Contractor is solely responsible for determining whether a hazardous condition exists or is created during the course of the Work, involving a risk of bodily harm to any person or risk of damage to any property. If a hazardous condition exists or is created, Contractor must take all precautions necessary to address the condition and ensure that the Work progresses safely under the circumstances. Hazardous conditions may result from, but are not limited to, use of specified materials or equipment, the Work location, the Project site condition, the method of construction, or the way any Work must be performed.

10.5 Emergencies. In an emergency affecting the safety or protection of persons, Work, or property at or adjacent to any Worksite, Contractor must take reasonable and prompt actions to prevent damage, injury, or loss, without prior authorization from the City if, under the circumstances, there is inadequate time to seek prior authorization from the City.

Article 11 - Completion and Warranty Provisions

11.1 Final Completion.

(A) **Final Inspection and Punch List.** When the Work required by this Contract is fully performed, Contractor must provide written notification to City requesting final inspection. The Engineer will schedule the date and time for final inspection, which must include Contractor's primary representative for this Project and its superintendent. Based on that inspection, City will prepare a punch list of any items that are incomplete, missing, defective, incorrectly installed, or otherwise not compliant with the Contract Documents. The punch list to Contractor will specify the time by which all of the punch list items must be completed or corrected. The punch list may include City's estimated cost to complete each punch list item if Contractor fails to do so within the specified time. The omission of any non-compliant item from a punch list will not relieve Contractor from fulfilling all requirements of the Contract Documents. Contractor's failure to complete any punch list item within the time specified in the punch list will not waive or abridge its warranty obligations for any such items that must be completed by the City or by a third party retained by the City due to Contractor's failure to timely complete any such outstanding item.

(B) **Requirements for Final Completion.** Final Completion will be achieved upon completion or correction of all punch list items, as verified by City's further inspection, and upon satisfaction of all other Contract requirements, including any commissioning required under the Contract Documents and submission of all final submittals, including instructions and manuals as required under Section 7.10, and complete, final as-built drawings as required under Section 7.11, all to City's satisfaction.

(C) **Acceptance.** The Project will be considered accepted upon City Council action during a public meeting to accept the Project, unless the Engineer is authorized to accept the Project, in which case the Project will be considered accepted upon the date of the Engineer's issuance of a written notice of acceptance. In order to avoid delay of Project close out, the City may elect, acting in its sole discretion, to accept the Project as complete subject to exceptions for punch list items that are not completed within the time specified in the punch list.

(D) **Final Payment and Release of Retention.** Final Payment and release of retention, less any sums withheld pursuant to the provisions of the Contract Documents, will not be made sooner than 35 days after recordation of the notice of completion. If Contractor fails to complete all of the punch list items within the specified time, City may withhold up to 150% of City's estimated cost to complete each of the remaining items from Final Payment and may use the withheld retention to pay for the costs to self-perform the outstanding items or to retain a third party to complete any such outstanding punch list item.

11.2 Warranty.

(A) **General.** Contractor warrants that all materials and equipment will be new unless otherwise specified, of good quality, in conformance with the Contract Documents, and free from defective workmanship and materials. Contractor further warrants that the Work will be free from material defects not intrinsic in the design or materials required in the Contract Documents. Contractor warrants that materials or items incorporated into the Work comply with the requirements and standards in the Contract Documents, including compliance with Laws, and that any Hazardous Materials encountered or used were handled as required by Laws. At City's request, Contractor must furnish satisfactory evidence of the quality and type of materials and equipment furnished. Contractor's warranty does not extend to damage caused by normal wear and tear, or improper use or maintenance.

(B) **Warranty Period.** Contractor's warranty must guarantee its Work for a period of one year from the date of Project acceptance (the "Warranty Period"), except when a longer guarantee is provided by a supplier or manufacturer or is required by the Specifications or Special Conditions. Contractor must obtain from its Subcontractors, suppliers and manufacturers any special or extended warranties required by the Contract Documents.

(C) **Warranty Documents.** As a condition precedent to Final Completion, Contractor must supply City with all warranty and guarantee documents relevant to equipment and materials incorporated into the Work and guaranteed by their suppliers or manufacturers.

(D) **Subcontractors.** The warranty obligations in the Contract Documents apply to Work performed by Contractor and its Subcontractors, and Contractor agrees to be co-guarantor of such Work.

(E) **Contractor's Obligations.** Upon written notice from City to Contractor of any defect in the Work discovered during the Warranty Period, Contractor or its responsible Subcontractor must promptly correct the defective Work at its own cost. Contractor's obligation to correct defects discovered during the Warranty Period will continue past the expiration of the Warranty Period as to any defects in Work for which Contractor was notified prior to expiration of the Warranty Period. Work performed during the Warranty Period ("Warranty Work") will be subject to the warranty provisions in this Section 11.2 for a one-year period that begins upon completion of such Warranty Work to City's satisfaction.

(F) **City's Remedies.** If Contractor or its responsible Subcontractor fails to correct defective Work within ten days following notice by City, or sooner if required by the circumstances, City may correct the defects to conform with the Contract Documents at Contractor's sole expense. Contractor must reimburse City for its costs in accordance with subsection (H), below.

(G) **Emergency Repairs.** In cases of emergency where any delay in correcting defective Work could cause harm, loss or damage, City may immediately correct the defects to conform with the Contract Documents at Contractor's sole expense. Contractor or its surety must reimburse City for its costs in accordance with subsection (H), below.

(H) **Reimbursement.** Contractor must reimburse City for its costs to repair under subsections (F) or (G), above, within 30 days following City's submission of a demand for payment pursuant to this provision. If City is required to initiate legal action to compel Contractor's compliance with this provision, and City is the prevailing party in such action, Contractor and its surety are solely responsible for all of City's attorney's fees and legal costs expended to enforce Contractor's warranty obligations herein, in addition to any and all costs City incurs to correct the defective Work.

11.3 Use Prior to Final Completion. City reserves the right to occupy or make use of the Project, or any portions of the Project, prior to Final Completion if City has determined that the Project or portion of it is in a condition suitable for the proposed occupation or use, and that it is in its best interest to occupy or make use of the Project, or any portions of it, prior to Final Completion.

(A) **Non-Waiver.** Occupation or use of the Project, in whole or in part, prior to Final Completion will not operate as acceptance of the Work or any portion of it, nor will it operate as a waiver of any of City's rights or Contractor's duties pursuant to these Contract Documents, and will not affect nor bear on the determination of the time of substantial completion with respect to any statute of repose pertaining to the time for filing an action for construction defect.

(B) **City's Responsibility.** City will be responsible for the cost of maintenance and repairs due to normal wear and tear with respect to those portions of the Project that are being occupied or used before Final Completion. The Contract Price or the Contract Time may be adjusted pursuant to the applicable provisions of these Contract Documents if, and only to the extent that, any occupation or use under this Section actually adds to Contractor's cost or time to complete the Work within the Contract Time.

11.4 Substantial Completion. For purposes of determining "substantial completion" with respect to any statute of repose pertaining to the time for filing an action for construction defect, "substantial completion" is deemed to mean the last date that Contractor or any Subcontractor performs Work on the Project prior to City acceptance of the Project, except for warranty work performed under this Article.

Article 12 - Dispute Resolution

12.1 Claims. This Article applies to and provides the exclusive procedures for any Claim arising from or related to the Contract or performance of the Work.

(A) **Limitations.** A Claim may only include the portion of a previously rejected demand that remains in dispute between Contractor and City. With the exception of any dispute regarding the amount of money actually paid to Contractor as Final Payment,

Contractor is not entitled to submit a Claim demanding a change in the Contract Time or the Contract Price, which has not previously been submitted to City in full compliance with Article 5 and Article 6, and subsequently rejected in whole or in part by City.

(B) **Scope of Article.** This Article is intended to provide the exclusive procedures for submission and resolution of Claims of any amount and applies in addition to the provisions of Public Contract Code § 9204 and § 20104 et seq., which are incorporated by reference herein.

(C) **No Work Delay.** Notwithstanding the submission of a Claim or any other dispute between the parties related to the Project or the Contract Documents, Contractor must perform the Work and may not delay or cease Work pending resolution of a Claim or other dispute, but must continue to diligently prosecute the performance and timely completion of the Work, including the Work pertaining to the Claim or other dispute.

(D) **Informal Resolution.** Contractor will make a good faith effort to informally resolve a dispute before initiating a Claim, preferably by face-to-face meeting between authorized representatives of Contractor and City.

12.2 Claims Submission. The following requirements apply to any Claim subject to this Article:

(A) **Substantiation.** The Claim must be submitted to City in writing, by registered or certified mail with return receipt requested and clearly identified as a “Claim” submitted pursuant to this Article 12. The Claim must include all of the documents necessary to substantiate the Claim including the Change Order request that was rejected in whole or in part, and a copy of City’s written rejection that is in dispute. The Claim must clearly identify and describe the dispute, including relevant references to applicable portions of the Contract Documents, and a chronology of relevant events. Any Claim for additional payment must include a complete, itemized breakdown of all known or estimated labor, materials, taxes, insurance, and subcontract, or other costs. Substantiating documentation such as payroll records, receipts, invoices, or the like, must be submitted in support of each component of claimed cost. Any Claim for an extension of time or delay costs must be substantiated with a schedule analysis and narrative depicting and explaining claimed time impacts.

(B) **Claim Format and Content.** A Claim must be submitted in the following format:

- (1) Provide a cover letter, specifically identifying the submission as a “Claim” submitted under this Article 12 and specifying the requested remedy (e.g., amount of proposed change to Contract Price and/or change to Contract Time).
- (2) Provide a summary of each Claim, including underlying facts and the basis for entitlement, and identify each specific demand at issue, including the specific Change Order request (by number and submittal date), and the date of City’s rejection of that demand, in whole or in part.
- (3) Provide a detailed explanation of each issue in dispute. For multiple issues included within a single Claim or for multiple Claims submitted concurrently, separately number and identify each individual issue or Claim, and include the following for each separate issue or Claim:
 - a. A succinct statement of the matter in dispute, including Contractor’s position and the basis for that position;

- b. Identify and attach all documents that substantiate the Claim, including relevant provisions of the Contract Documents, RFIs, calculations, and schedule analysis (see subsection (A), Substantiation, above);
- c. A chronology of relevant events; and
- d. Analysis and basis for claimed changes to Contract Price, Contract Time, or any other remedy requested.

(4) Provide a summary of issues and corresponding claimed damages. If, by the time of the Claim submission deadline (below), the precise amount of the requested change in the Contract Price or Contract Time is not yet known, Contractor must provide a good faith estimate, including the basis for that estimate, and must identify the date by which it is anticipated that the Claim will be updated to provide final amounts.

(5) Include the following certification, executed by Contractor's authorized representative:

"The undersigned Contractor certifies under penalty of perjury that its statements and representations in this Claim submittal are true and correct. Contractor warrants that this Claim submittal is comprehensive and complete as to the matters in dispute, and agrees that any costs, expenses, or delay not included herein are deemed waived."

(C) **Submission Deadlines.**

(1) A Claim disputing rejection of a request for a change in the Contract Time or Contract Price must be submitted within 21 days following the date that City notified Contractor in writing that a request for a change in the Contract Time or Contract Price, duly submitted in compliance with Article 5 and Article 6, has been rejected in whole or in part. A Claim disputing the terms of a unilateral Change Order must be submitted within 21 days following the date of issuance of the unilateral Change Order. These Claim deadlines apply even if Contractor cannot yet quantify the total amount of any requested change in the Contract Time or Contract Price. If the Contractor cannot quantify those amounts, it must submit an estimate of the amounts claimed pending final determination of the requested remedy by Contractor.

(2) With the exception of any dispute regarding the amount of Final Payment, any Claim must be filed on or before the date of Final Payment or will be deemed waived.

(3) A Claim disputing the amount of Final Payment must be submitted within 21 days of the effective date of Final Payment, under Section 8.7, Final Payment.

(4) Strict compliance with these Claim submission deadlines is necessary to ensure that any dispute may be mitigated as soon as possible, and to facilitate cost-efficient administration of the Project. **Any Claim that is not submitted within the specified deadlines will be deemed waived by Contractor.**

12.3 City's Response. City will respond within 45 days of receipt of the Claim with a written statement identifying which portion(s) of the Claim are disputed, unless the 45-day period is extended by mutual agreement of City and Contractor or as otherwise allowed under Public Contract Code § 9204. However, if City determines that the Claim is not

adequately substantiated pursuant to Section 12.2(A), Substantiation, City may first request in writing, within 30 days of receipt of the Claim, any additional documentation supporting the Claim or relating to defenses to the Claim that City may have against the Claim.

(A) **Additional Information.** If additional information is thereafter required, it may be requested and provided upon mutual agreement of City and Contractor. If Contractor's Claim is based on estimated amounts, Contractor has a continuing duty to update its Claim as soon as possible with information on actual amounts in order to facilitate prompt and fair resolution of the Claim.

(B) **Non-Waiver.** Any failure by City to respond within the times specified above will not be construed as acceptance of the Claim, in whole or in part, or as a waiver of any provision of these Contract Documents.

12.4 Meet and Confer. If Contractor disputes City's written response, or City fails to respond within the specified time, within 15 days of receipt of City's response or within 15 days of City's failure to respond within the applicable 45-day time period under Section 12.3, respectively, Contractor may notify City of the dispute in writing sent by registered or certified mail, return receipt requested, and demand an informal conference to meet and confer for settlement of the issues in dispute. If Contractor fails to notify City of the dispute and demand an informal conference to meet and confer in writing within the specified time, Contractor's Claim will be deemed waived.

(A) **Schedule Meet and Confer.** Upon receipt of the demand to meet and confer, City will schedule the meet and confer conference to be held within 30 days, or later if needed to ensure the mutual availability of each of the individuals that each party requires to represent its interests at the meet and confer conference.

(B) **Location for Meet and Confer.** The meet and confer conference will be scheduled at a location at or near City's principal office.

(C) **Written Statement After Meet and Confer.** Within ten working days after the meet and confer has concluded, City will issue a written statement identifying which portion(s) of the Claim remain in dispute, if any.

(D) **Submission to Mediation.** If the Claim or any portion remains in dispute following the meet and confer conference, within ten working days after the City issues the written statement identifying any portion(s) of the Claim remaining in dispute, the Contractor may identify in writing disputed portion(s) of the Claim, which will be submitted for mediation, as set forth below.

12.5 Mediation and Government Code Claims.

(A) **Mediation.** Within ten working days after the City issues the written statement identifying any portion(s) of the Claim remaining in dispute following the meet and confer, City and Contractor will mutually agree to a mediator, as provided under Public Contract Code § 9204. Mediation will be scheduled to ensure the mutual availability of the selected mediator and all of the individuals that each party requires to represent its interests. If there are multiple Claims in dispute, the parties may agree to schedule the mediation to address all outstanding Claims at the same time. The parties will share the costs of the mediator and mediation fees equally, but each party is otherwise solely and separately responsible for its own costs to prepare for and participate in the mediation, including costs for its legal counsel or any other consultants.

(B) **Government Code Claims.**

(1) Timely presentation of a Government Code Claim is a condition precedent to filing any legal action based on or arising from the Contract. Compliance with the Claim submission requirements in this Article 12 is a condition precedent to filing a Government Code Claim.

(2) The time for filing a Government Code Claim will be tolled from the time Contractor submits its written Claim pursuant to Section 12.2, above, until the time that Claim is denied in whole or in part at the conclusion of the meet and confer process, including any period of time used by the meet and confer process. However, if the Claim is submitted to mediation, the time for filing a Government Code Claim will be tolled until conclusion of the mediation, including any continuations, if the Claim is not fully resolved by mutual agreement of the parties during the mediation or any continuation of the mediation.

12.6 Tort Claims. This Article does not apply to tort claims and nothing in this Article is intended nor will be construed to change the time periods for filing tort-based Government Code Claims.

12.7 Arbitration. It is expressly agreed, under Code of Civil Procedure § 1296, that in any arbitration to resolve a dispute relating to this Contract, the arbitrator's award must be supported by law and substantial evidence.

12.8 Burden of Proof and Limitations. Contractor bears the burden of proving entitlement to and the amount of any claimed damages. Contractor is not entitled to damages calculated on a total cost basis, but must prove actual damages. Contractor is not entitled to speculative, special, or consequential damages, including home office overhead or any form of overhead not directly incurred at the Project site or any other Worksite; lost profits; loss of productivity; lost opportunity to work on other projects; diminished bonding capacity; increased cost of financing for the Project; extended capital costs; non-availability of labor, material or equipment due to delays; or any other indirect loss arising from the Contract. The Eichleay Formula or similar formula will not be used for any recovery under the Contract. The City will not be directly liable to any Subcontractor or supplier.

12.9 Legal Proceedings. In any legal proceeding that involves enforcement of any requirements of the Contract Documents, the finder of fact will receive detailed instructions on the meaning and operation of the Contract Documents, including conditions, limitations of liability, remedies, claim procedures, and other provisions bearing on the defenses and theories of liability. Detailed findings of fact will be requested to verify enforcement of the Contract Documents. All of the City's remedies under the Contract Documents will be construed as cumulative, and not exclusive, and the City reserves all rights to all remedies available under law or equity as to any dispute arising from or relating to the Contract Documents or performance of the Work.

12.10 Other Disputes. The procedures in this Article 12 will apply to any and all disputes or legal actions, in addition to Claims, arising from or related to this Contract, including disputes regarding suspension or early termination of the Contract, unless and only to the extent that compliance with a procedural requirement is expressly and specifically waived by City. Nothing in this Article is intended to delay suspension or termination under Article 13.

Article 13 - Suspension and Termination

13.1 Suspension for Cause. In addition to all other remedies available to City, if Contractor fails to perform or correct Work in accordance with the Contract Documents, including non-compliance with applicable environmental or health and safety Laws, City may immediately order the Work, or any portion of it, suspended until the circumstances giving rise to the suspension have been eliminated to City's satisfaction.

(A) **Notice of Suspension.** Upon receipt of City's written notice to suspend the Work, in whole or in part, except as otherwise specified in the notice of suspension, Contractor and its Subcontractors must promptly stop Work as specified in the notice of suspension; comply with directions for cleaning and securing the Worksite; and protect the completed and in-progress Work and materials. Contractor is solely responsible for any damages or loss resulting from its failure to adequately secure and protect the Project.

(B) **Resumption of Work.** Upon receipt of the City's written notice to resume the suspended Work, in whole or in part, except as otherwise specified in the notice to resume, Contractor and its Subcontractors must promptly re-mobilize and resume the Work as specified; and within ten days from the date of the notice to resume, Contractor must submit a recovery schedule, prepared in accordance with the Contract Documents, showing how Contractor will complete the Work within the Contract Time.

(C) **Failure to Comply.** Contractor will not be entitled to an increase in the Contract Time or Contract Price for a suspension occasioned by Contractor's failure to comply with the Contract Documents.

(D) **No Duty to Suspend.** City's right to suspend the Work will not give rise to a duty to suspend the Work, and City's failure to suspend the Work will not constitute a defense to Contractor's failure to comply with the requirements of the Contract Documents.

13.2 Suspension for Convenience. City reserves the right to suspend, delay, or interrupt the performance of the Work in whole or in part, for a period of time determined to be appropriate for City's convenience. Upon notice by City pursuant to this provision, Contractor must immediately suspend, delay, or interrupt the Work and secure the Project site as directed by City except for taking measures to protect completed or in-progress Work as directed in the suspension notice, and subject to the provisions of Section 13.1(A) and (B), above. If Contractor submits a timely request for a Change Order in compliance with Articles 5 and 6, the Contract Price and the Contract Time will be equitably adjusted by Change Order pursuant to the terms of Articles 5 and 6 to reflect the cost and delay impact occasioned by such suspension for convenience, except to the extent that any such impacts were caused by Contractor's failure to comply with the Contract Documents or the terms of the suspension notice or notice to resume. However, the Contract Time will only be extended if the suspension causes or will cause unavoidable delay in Final Completion. If Contractor disputes the terms of a Change Order issued for such equitable adjustment due to suspension for convenience, its sole recourse is to comply with the Claim procedures in Article 12.

13.3 Termination for Default. City may declare that Contractor is in default of the Contract for a material breach of or inability to fully, promptly, or satisfactorily perform its obligations under the Contract.

(A) **Default.** Events giving rise to a declaration of default include Contractor's refusal or failure to supply sufficient skilled workers, proper materials, or equipment to perform the Work within the Contract Time; Contractor's refusal or failure to make prompt payment to its employees, Subcontractors, or suppliers or to correct defective Work or

damage; Contractor's failure to comply with Laws, or orders of any public agency with jurisdiction over the Project; evidence of Contractor's bankruptcy, insolvency, or lack of financial capacity to complete the Work as required within the Contract Time; suspension, revocation, or expiration and nonrenewal of Contractor's license or DIR registration; dissolution, liquidation, reorganization, or other major change in Contractor's organization, ownership, structure, or existence as a business entity; unauthorized assignment of Contractor's rights or duties under the Contract; or any material breach of the Contract requirements.

(B) **Notice of Default and Opportunity to Cure.** Upon City's declaration that Contractor is in default due to a material breach of the Contract Documents, if City determines that the default is curable, City will afford Contractor the opportunity to cure the default within ten days of City's notice of default, or within a period of time reasonably necessary for such cure, including a shorter period of time if applicable.

(C) **Termination.** If Contractor fails to cure the default or fails to expediently take steps reasonably calculated to cure the default within the time period specified in the notice of default, City may issue written notice to Contractor and its performance bond surety of City's termination of the Contract for default.

(D) **Waiver.** Time being of the essence in the performance of the Work, if Contractor's surety fails to arrange for completion of the Work in accordance with the Performance Bond within seven calendar days from the date of the notice of termination pursuant to paragraph (C), City may immediately make arrangements for the completion of the Work through use of its own forces, by hiring a replacement contractor, or by any other means that City determines advisable under the circumstances. Contractor and its surety will be jointly and severally liable for any additional cost incurred by City to complete the Work following termination, where "additional cost" means all cost in excess of the cost City would have incurred if Contractor had timely completed Work without the default and termination. In addition, City will have the right to immediate possession and use of any materials, supplies, and equipment procured for the Project and located at the Project site or any Worksite on City property for the purposes of completing the remaining Work.

(E) **Compensation.** Within 30 days of receipt of updated as-builts, all warranties, manuals, instructions, or other required documents for Work installed to date, and delivery to City of all equipment and materials for the Project for which Contractor has already been compensated, Contractor will be compensated for the Work satisfactorily performed in compliance with the Contract Documents up to the effective date of the termination pursuant to the terms of Article 8, Payment, subject to City's rights to withhold or deduct sums from payment otherwise due pursuant to Section 8.3, and excluding any costs Contractor incurs as a result of the termination, including any cancellation or restocking charges or fees due to third parties. If Contractor disputes the amount of compensation determined by City, its sole recourse is to comply with the Claim Procedures in Article 12, by submitting a Claim no later than 30 days following notice from City of the total compensation to be paid by City.

(F) **Wrongful Termination.** If Contractor disputes the termination, its sole recourse is to comply with the Claim procedures in Article 12. If a court of competent jurisdiction or an arbitrator later determines that the termination for default was wrongful, the termination will be deemed to be a termination for convenience, and Contractor's damages will be strictly limited to the compensation provided for termination for convenience under Section 13.4, below. Contractor waives any claim for any other damages for wrongful termination including special or consequential damages, lost opportunity costs, or lost profits, and any award of damages is subject to Section 12.8, Burden of Proof and Limitations.

13.4 Termination for Convenience. City reserves the right, acting in its sole discretion, to terminate all or part of the Contract for convenience upon written notice to Contractor.

(A) **Compensation to Contractor.** In the event of City's termination for convenience, Contractor waives any claim for damages, including for loss of anticipated profits from the Project. The following will constitute full and fair compensation to Contractor, and Contractor will not be entitled to any additional claim or compensation:

(1) **Completed Work.** The value of its Work satisfactorily performed as of the date notice of termination is received, based on Contractor's schedule of values and unpaid costs for items delivered to the Project site that were fabricated for incorporation in the Work;

(2) **Demobilization.** Demobilization costs specified in the schedule of values, or if demobilization costs were not provided in a schedule of values pursuant to Section 8.1, then based on actual, reasonable, and fully documented demobilization costs; and

(3) **Termination Markup.** Five percent of the total value of the Work performed as of the date of notice of termination, including reasonable, actual, and documented costs to comply with the direction in the notice of termination for convenience, and demobilization costs, which is deemed to cover all overhead and profit to date.

(B) **Disputes.** If Contractor disputes the amount of compensation determined by City pursuant to paragraph (A), above, its sole recourse is to comply with the Claim procedures in Article 12, by submitting a Claim no later than 30 days following notice from City of total compensation to be paid by City.

13.5 Actions Upon Termination for Default or Convenience. The following provisions apply to any termination under this Article, whether for default or convenience, and whether in whole or in part.

(A) **General.** Upon termination, City may immediately enter upon and take possession of the Project and the Work and all tools, equipment, appliances, materials, and supplies procured or fabricated for the Project. Contractor will transfer title to and deliver all completed Work and all Work in progress to City.

(B) **Submittals.** Unless otherwise specified in the notice of termination, Contractor must immediately submit to City all designs, drawings, as-built drawings, Project records, contracts with vendors and Subcontractors, manufacturer warranties, manuals, and other such submittals or Work-related documents required under the terms of the Contract Documents, including incomplete documents or drafts.

(C) **Close Out Requirements.** Except as otherwise specified in the notice of termination, Contractor must comply with all of the following:

(1) Immediately stop the Work, except for any Work that must be completed pursuant to the notice of termination and comply with City's instructions for cessation of labor and securing the Project and any other Worksite(s).

(2) Comply with City's instructions to protect the completed Work and materials, using best efforts to minimize further costs.

(3) Contractor must not place further orders or enter into new subcontracts for materials, equipment, services or facilities, except as may be necessary to complete any portion of the Work that is not terminated.

(4) As directed in the notice, Contractor must assign to City or cancel existing subcontracts that relate to performance of the terminated Work, subject to any prior rights, if any, of the surety for Contractor's performance bond, and settle all outstanding liabilities and claims, subject to City's approval.

(5) As directed in the notice, Contractor must use its best efforts to sell any materials, supplies, or equipment intended solely for the terminated Work in a manner and at market rate prices acceptable to City.

(D) **Payment Upon Termination.** Upon completion of all termination obligations, as specified herein and in the notice of termination, Contractor will submit its request for Final Payment, including any amounts due following termination pursuant to this Article 13. Payment will be made in accordance with the provisions of Article 8, based on the portion of the Work satisfactorily completed, including the close out requirements, and consistent with the previously submitted schedule of values and unit pricing, including demobilization costs. Adjustments to Final Payment may include deductions for the cost of materials, supplies, or equipment retained by Contractor; payments received for sale of any such materials, supplies, or equipment, less re-stocking fees charged; and as otherwise specified in Section 8.3, Adjustment of Payment Application.

(E) **Continuing Obligations.** Regardless of any Contract termination, Contractor's obligations for portions of the Work already performed will continue and the provisions of the Contract Documents will remain in effect as to any claim, indemnity obligation, warranties, guarantees, submittals of as-built drawings, instructions, or manuals, record maintenance, or other such rights and obligations arising prior to the termination date.

Article 14 - Miscellaneous Provisions

- 14.1 Assignment of Unfair Business Practice Claims.** Under Public Contract Code § 7103.5, Contractor and its Subcontractors agree to assign to City all rights, title, and interest in and to all causes of action it may have under section 4 of the Clayton Act (15 U.S.C. § 15) or under the Cartwright Act (Chapter 2 (commencing with § 16700) of Part 2 of Division 7 of the Business and Professions Code), arising from purchases of goods, services, or materials pursuant to the Contract or any subcontract. This assignment will be effective at the time City tenders Final Payment to Contractor, without further acknowledgement by the parties.
- 14.2 Provisions Deemed Inserted.** Every provision of law required to be inserted in the Contract Documents is deemed to be inserted, and the Contract Documents will be construed and enforced as though such provision has been included. If it is discovered that through mistake or otherwise that any required provision was not inserted, or not correctly inserted, the Contract Documents will be deemed amended accordingly.
- 14.3 Waiver.** City's waiver of a breach, failure of any condition, or any right or remedy contained in or granted by the provisions of the Contract Documents will not be effective unless it is in writing and signed by City. City's waiver of any breach, failure, right, or remedy will not be deemed a waiver of any other breach, failure, right, or remedy, whether or not similar, nor will any waiver constitute a continuing waiver unless specified in writing by City.

- 14.4 Titles, Headings, and Groupings.** The titles and headings used and the groupings of provisions in the Contract Documents are for convenience only and may not be used in the construction or interpretation of the Contract Documents or relied upon for any other purpose.
- 14.5 Statutory and Regulatory References.** With respect to any amendments to any statutes or regulations referenced in these Contract Documents, the reference is deemed to be the version in effect on the date that bids were due.
- 14.6 Survival.** The provisions that survive termination or expiration of this Contract include Contract Section 11, Notice, and subsections 12.1, 12.2, 12.3, 12.4, 12.5, and 12.6 of Section 12, General Provisions; and the following provisions in these General Conditions: Section 2.2(J), Contractor's Records, Section 2.3(C), Termination, Section 3.7, Ownership, Section 4.2, Indemnity, Article 12, Dispute Resolution, and Section 11.2, Warranty.

END OF GENERAL CONDITIONS

Special Conditions

1. Authorized Work Days and Hours.

- 1.1 Authorized Work Days.** Except as expressly authorized in writing by City, Contractor is limited to performing Work on the Project on the following days of the week, excluding holidays observed by City: Monday through Friday.
- 1.2 Authorized Work Hours.** Except as expressly authorized in writing by City, Contractor is limited to performing Work on the Project during the following hours: 9:00 a.m. to 3:00 p.m. during school in session. Work hours may change to 7:30 a.m. to 4:00 p.m. with City Engineer approval.

2. Pre-Construction Conference. City will designate a date and time for a pre-construction conference with Contractor following Contract execution. Project administration procedures and coordination between City and Contractor will be discussed, and Contractor must present City with the following information or documents at the meeting for City's review and acceptance before the Work commences:

- 2.1** Name, 24-hour contact information, and qualifications of the proposed on-site superintendent;
- 2.2** List of all key Project personnel and their complete contact information, including email addresses and telephone numbers during regular hours and after hours;
- 2.3** Staging plans that identify the sequence of the Work, including any phases and alternative sequences or phases, with the goal of minimizing the impacts on residents, businesses and other operations in the Project vicinity;
- 2.4** Draft baseline schedule for the Work as required under Section 5.2 of the General Conditions, to be finalized within ten days after City issues the Notice to Proceed;
- 2.5** Schedule with list of Project submittals that require City review, and list of the proposed material suppliers;
- 2.6** Videotape and photographs recording the conditions throughout the pre-construction Project site, showing the existing improvements and current condition of the curbs, gutters, sidewalks, signs, landscaping, streetlights, structures near the Project such as building faces, canopies, shades and fences, and any other features within the Project area limits;
- 2.7** Any other documents specified in the Special Conditions or Notice of Potential Award.

3. Insurance Requirements. The insurance requirements under Section 4.3 of the General Conditions are modified for this Contract, as set forth below. Except as expressly stated below, all other provisions in Section 4.3 are unchanged and remain in full force and effect.

- 3.1 Commercial General Liability ("CGL") Insurance.** The CGL insurance policy limits set forth in subsection 4.3(A)(1) of the General Conditions are modified for this Contract to require at least \$2,000,000 per occurrence and at least \$4,000,000 general aggregate.

3.2 Builders Risk Insurance Waived. The builder's risk insurance policy requirement set forth in subsection 4.3(A)(5) of the General Conditions is hereby waived and does not apply to this Contract.

4. Close Out Requirements. Contractor's close out requirements include the following, if applicable:

- 4.1** Contractor must replace, with thermoplastic, any existing striping within and adjacent to the Project site that is damaged during the Work. Partially damaged striping must be replaced in its entirety.
- 4.2** Contractor must replace any survey monuments that are damaged or removed during the Work, with a Record of Survey filed by a licensed land surveyor as required by California law.
- 4.3** Before removing any traffic control or street signs on the Project site, Contractor must take photographs showing their original locations. Upon completion of each phase of construction, Contractor must temporarily reset the signs at those locations. Contractor must then replace the signs permanently upon completion of the Work and the cost of their removal and replacement must be included in the Bid Proposal.
- 4.4** Contractor must maintain any rural mail boxes on the Project site and relocate them to their permanent locations as soon as possible in the course of the Work, to the satisfaction of the affected property owners and the postal service.

END OF SPECIAL CONDITIONS

TECHNICAL SPECIFICATIONS

TECHNICAL SPECIFICATIONS	79
SECTION 01010 – SUMMARY OF WORK	80
SECTION 01015 – SUMMARY OF BID ITEMS	82
SECTION 01200 – PROJECT MEETINGS	87
SECTION 01300 – SUBMITTALS	89
SECTION 01310 – CONSTRUCTION SCHEDULE	93
SECTION 01500 – ADJACENT PROPERTY OWNERS	95
SECTION 01505 – MOBILIZATION	99
SECTION 01600 – STORM WATER EROSION/POLLUTION CONTROL	101
SECTION 01650 – DUST CONTROL	107
SECTION 01700 – EXISTING FACILITIES	108
SECTION 01800 – TRAFFIC AND ACCESS CONTROL	113
SECTION 02220 – DEMOLITION	116
SECTION 02225 – CLEARING AND GRUBBING	118
SECTION 02230 – TREE REMOVAL	120
SECTION 02400 – LINES AND GRADE	122
SECTION 02500 – AGGREGATE BASE	123
SECTION 03200 – STEEL REINFORCEMENT	125
SECTION 03300 – CAST-IN-PLACE CONCRETE	128
SECTION 03315 – TRUNCATED DOMES	132
SECTION 03400 – ASPHALT CONCRETE	133
SECTION 04000 – STRIPING AND MARKINGS	138
SECTION 04100 – SIGNING	141

SECTION 01010 – SUMMARY OF WORK

PART 1 - GENERAL

1.1 SCOPE OF WORK

- A. The work to be completed consists of removing and replacing concrete sidewalk, American with Disabilities Act (ADA) ramps, driveway approach, curb and gutter; adjusting utilities to grade; and all other work necessary to construct the project complete and in satisfactory condition, all as shown on the Contract Documents and/or as specified herein..

1.2 LOCATION

- A. The location of the work is at the following locations in Brentwood, CA:

1. Central Boulevard
2. Pondlilly Lane
3. Citywide Locations per Project Plans

1.3 START OF WORK

- A. Contractor shall not start work until after a receipt of a Notice to Proceed issued by the Project Manager. The Contractor shall notify the City of Brentwood at least two weeks prior to the intended start date.
- B. Hours of work shall conform to the Special Conditions.
- C. The Contractor must control operations such that the following conditions can be met:
 1. All work shall be coordinated with the Traffic Control Plan, Project Schedule, Submittals and other requirements of the Contract Documents.
 2. Any modification to the traffic control shall be approved in writing in advance by the City Engineer.
 3. The ADA curb ramps shall be completed before any other work commences.

1.4 PROJECT INFORMATION

- A. Project Management Documentation and Administration

1. The agency reserves the right to utilize an online cloud-based project management system. Virtual Project Manager (VPM) allows for paperless documentation and project administration. For more information, go to www.virtual-pm.com.
2. See Section 01300 Submittals for requirements for administering and using VPM.

1.5 PERMITS

- A. The Contractor shall ensure that all necessary permits and licenses have been granted prior to commencing work. The Contractor shall not proceed to work in areas requiring permits or licenses until such are obtained.
- B. The Contractor shall not hold the City liable for any delays in obtaining any and all permits, licenses or permissions to construct as long as the Contractor has items of work that could be accomplished besides those items that require permits. Additional working days may be allowed due to permit delays at the discretion of the City Engineer. Payment for any work and/or coordination related to obtaining permits and for conforming to the requirements of this section shall be considered as included in the prices paid for the various contract items of work involved and no additional compensation will be allowed. However, the City of Brentwood shall pay all permit fees.
- C. The Contractor shall notify the City Engineer in writing of pending permit delays five (5) working days before the delay will affect progress of work. If the City Engineer approves the request for permit delays, additional working day calculations will only be allowed to start five (5) days after Contractor notifies the City Engineer in writing of pending permit delays.

1.6 ELECTRIC POWER

- A. The Contractor shall furnish electric power required to perform the work.
- B. The Contractor shall be responsible to coordinate with PG&E to energize all electrical systems for the project. The Contractor shall be responsible for payment of electricity costs until all electrical facilities are accepted by the City. The Contractor is responsible for maintenance of the electrical systems until acceptance of the entire project by the City.

PART 2 - MATERIALS

NOT USED

PART 3 - EXECUTION

NOT USED

PART 4 - PAYMENT

4.1 MEASUREMENT AND PAYMENT

- A. Full compensation for furnishing all labor, materials, tools, equipment, and incidentals necessary to perform all work required to conform to this Section shall be considered as included in the Contract prices paid for the various bid items of work involved and no additional compensation will be allowed.

++ END OF SECTION ++

SECTION 01015 – SUMMARY OF BID ITEMS

PART 1 - GENERAL

1.1 GENERAL

- A. Payment for the various items of the Bid Schedule, as further specified herein and in their respective section, shall include full compensation to be received by the Contractor for furnishing all labor, materials, tools, equipment and services necessary to perform all work for the construction, maintenance, testing, and placing of all items of work being described, including all appurtenances thereto and including the costs of all permits and the cost of compliance with the regulations of public agencies having jurisdiction, including Safety and Health Requirements of the California Division of Industrial Safety and the Occupational Safety and Health Administration of the U.S. Department of Labor (OSHA). No separate payment will be made for any item that is not specifically set forth in the Bid Schedule, and all costs therefor shall be included in the prices named in the Bid Schedule for the various items of work.

1.2 BID SCHEDULE

A. Bid Item 1 – Mobilization

1. **Mobilization** shall be measured by **lump sum** and paid for in accordance with Article 8 of the General Conditions.
2. The work associated with **Mobilization** shall include full compensation for furnishing all transportation, labor, materials, tools, equipment, and incidentals necessary to perform all work involved in mobilization, including but not limited to: obtaining bonds and insurance; schedule preparation and schedule updates; fees; obtaining and paying for all permits by other agencies (if applicable); movement of personnel, equipment, supplies to the site; protection of employees and the public, protection of the work from damage by fire, weather or vandalism; preparation, submission, and re-submission of submittals; schedule preparation; schedule updates; public notification; cleaning and site maintenance; survey layout; all construction facilities; temporary controls; demobilization; final cleaning and restoration of the job site; and turnover of the project to the City, as shown on the plans and specified in the Standard Specifications, General Conditions, and Technical Specifications and as directed by the City Engineer.
3. A 25% payment of the lump sum total will be paid with the first progress payment, 65% will be paid incrementally over the life of the Contract based on the percentage of the contract time completed to date, and the final 10% will be paid with the last progress payment.
4. The cost for mobilization shall not exceed **twenty (20) percent** of the total bid for this project without documented justification.
5. The cost for mobilization shall not be below **five (5) percent** of the total bid for this project without documented justification.

B. Bid Item 2 – Traffic Control

1. **Traffic Control** shall be measured by **lump sum** and paid for in accordance with Article 8 of the General Conditions.

2. The work associated with Traffic Control shall include full compensation for furnishing all transportation, labor, materials, tools, equipment, and incidentals necessary to perform all work involved in preparing and implementing the traffic control plan, including but not limited to: installing and maintaining traffic control; installing and maintaining temporary pavement delineation and markings; furnishing and placing barricades, warning devices, signage, flaggers; moving to new locations; detours for pedestrians, bicyclists, and vehicles as needed; and complying with the requirements as specified in this section, as described in the Contract Documents, as shown on the plans, as specified herein, and as directed by the City Engineer.
3. All flagging costs associated with the project are to be paid by the Contractor.
4. The adjustment provisions in Section 4-1.05, "Changes and Extra Work," of the Caltrans Standard Specifications shall not apply to the item of traffic control system. Adjustments in compensation for traffic control system will be made only for increased or decreased traffic control system required by changes ordered by the City Engineer and will be made on the basis of the cost of the increased or decreased traffic control necessary. The adjustment will be made on a force account basis as provided in Section 9-1.03, "Force Account," of the Caltrans Standard Specifications for increased work and estimated on the same basis in the case of decreased work.
5. For each **5-minute interval**, or fraction thereof past the time specified to reopen the lane closure, **\$100** per interval will be deducted from payment due or that may become due to the Contractor under the contract.

C. Bid Item 3 – **Storm Water Erosion/Pollution Control**

1. **Storm Water Erosion/Pollution Control** shall be measured by **lump sum** and paid for in accordance with Article 8 of the General Conditions.
2. The work associated with **Storm Water Erosion/Pollution Control** shall include full compensation for furnishing all transportation, labor, materials, tools, equipment, and incidentals necessary to perform all work involved in Storm Water Erosion/Pollution Control, including but not limited to: developing, implementing and obtaining approval of an Storm Water Erosion/Pollution Control Plan; inspecting, monitoring, and maintaining best management practices; and complying with the requirements as specified in this section, as described in the Contract Documents, as shown on the plans, as specified herein, and as directed by the City Engineer.
3. A 25% payment of the lump sum total will be paid with the first progress payment, 65% will be paid incrementally over the life of the Contract based on the percentage of the contract time completed to date, and the final 10% will be paid with the last progress payment.

D. Bid Item 4 – **Class 2 Aggregate Base**

1. **Class 2 Aggregate Base** shall be measured by **ton** and paid for in accordance with Article 8 of the General Conditions.
2. The work associated with **Class 2 Aggregate Base** shall include full compensation for furnishing all transportation, labor, materials, tools, equipment,

and incidentals necessary to perform all work involved in furnishing and placing aggregate base, including but not limited to: transporting, storing, placing, moisturizing, and compacting aggregate base; and complying with the requirements as specified in this section, as described in the Contract Documents, as shown on the plans, as specified herein, and as directed by the City Engineer.

3. Bid Item 4, Class 2 Aggregate Base, shall be for all Class 2 aggregate Base used on the project. This includes Bid Item 6 - Reconstruct Sidewalk, Bid Item 7 - Reconstruct Curb and Gutter, Bid Item 8 - Reconstruct Driveway Approach, and Bid Item 9 - Reconstruct ADA Ramp.

E. Bid Item 5 – **Remove and Replace Signs and Posts**

1. **Remove and Replace Signs and Posts** shall be measured by **each** and paid for in accordance with Article 8 of the General Conditions.
2. The work associated with **Remove and Replace Signs and Posts** shall include full compensation for furnishing all transportation, labor, materials, tools, equipment, and incidentals necessary to perform all work involved in removing and replacing the post; reinstalling signs; protecting surrounding area and utilities; and complying with the requirements as specified in this section, as described in the Contract Documents, as shown on the plans, as specified herein, and as directed by the City Engineer.

F. Bid Item 6 – **Reconstruct Sidewalk**

1. **Reconstruct Sidewalk** shall be measured by **square feet** and paid for in accordance with Article 8 of the General Conditions.
2. The work associated with **Reconstruct Sidewalk** shall include full compensation for furnishing all transportation, labor, materials, tools, equipment, and incidentals necessary to perform all work involved in reconstructing sidewalks, including but not limited to: sawcutting; root cutting; excavation; demolition; subgrade preparation; rebar installation; removal and disposal of excess materials; Portland cement concrete removal and replacement; dowels and reinforcement materials; repairing, replacing, or extending through-curb drains; and coordination with utility agencies; and complying with the requirements as specified in this section, as described in the Contract Documents, as shown on the plans, as specified herein, and as directed by the City Engineer.

G. Bid Item 7 – **Reconstruct Curb and Gutter**

1. **Reconstruct Curb and Gutter** shall be measured by **linear feet** and paid for in accordance with Article 8 of the General Conditions.
2. The work associated with **Reconstruct Curb and Gutter** shall include full compensation for furnishing all transportation, labor, materials, tools, equipment, and incidentals necessary to perform all work involved in reconstructing sidewalks, including but not limited to: sawcutting; root cutting; excavation; demolition; subgrade preparation; removal and disposal of excess materials; asphalt concrete removal and replacement as part of the reconstruction work; Portland cement concrete removal and replacement, dowels, reinforcement materials; repairing, replacing, or extending through-curb drains; coordination

with utility agencies; and all work as may be required by the Contract Documents, as specified herein, and as directed by the City Engineer.

3. Asphalt Concrete replaced in front of curb and gutters as part of reconstruction work, shall be considered as included in the contract unit price paid per linear foot and no additional compensation will be allowed.

H. Bid Item 8 – **Reconstruct Driveway Approach**

1. **Reconstruct Driveway Approach** shall be measured by **square feet** and paid for in accordance with Article 8 of the General Conditions.
2. The work associated with **Reconstruct Driveway Approach** shall include full compensation for furnishing all transportation, labor, materials, tools, equipment, and incidentals necessary to perform all work involved in reconstructing sidewalks, including but not limited to: sawcutting; root cutting; excavation; demolition; subgrade preparation; rebar installation; removal and disposal of excess materials; Portland cement concrete removal and replacement; dowels and reinforcement materials; repairing, replacing, or extending through-curb drains; coordination with utility agencies; and complying with the requirements as specified in this section, as described in the Contract Documents, as shown on the plans, as specified herein, and as directed by the City Engineer.

I. Bid Item 9 – **Reconstruct ADA Ramp**

1. **Reconstruct ADA Ramp** shall be measured by **each** and paid for in accordance with Article 8 of the General Conditions.
2. The work associated with **Reconstruct ADA Ramp** shall include full compensation for furnishing all transportation, labor, materials, tools, equipment, and incidentals necessary to perform all work involved in reconstructing ADA Ramps, including but not limited to: sawcutting; root cutting; excavation; demolition; subgrade preparation; removal and disposal of excess materials; asphalt concrete removal and replacement as part of the reconstruction work; Portland cement concrete removal and replacement; dowels and reinforcement materials; supplying and placement of truncated dome; coordination with utility agencies; and all work as may be required by the Contract Documents, as specified herein, and as directed by the City Engineer.
3. The cost for placement of one detectable warning surface per curb ramp shall be included and no additional compensation will be made.
4. Asphalt Concrete replaced in front of ADA Ramps as part of reconstruction work shall be considered as included in the contract unit price paid per square feet and no additional compensation will be allowed.

J. Bid Item 10 – **Adjust Utility to Grade**

1. **Adjust Utilities to Grade** shall be measured by **Each** and paid for in accordance with Article 8 of the General Conditions.
2. The work associated with **Adjust Utility to Grade** shall include, but are not limited to, full compensation for furnishing all transportation, labor, materials, tools, equipment, and incidentals necessary to perform all work involved in

adjusting utilities to grade in Portland cement concrete, including but not limited to: marking utilities by contacting USA, protecting utilities from damage, replacing damaged utilities and utility boxes, and conforming to the grade requirements in the American Disabilities Act and City of Brentwood Standard Plans; coordination with utility agencies; asphalt concrete; and all work as may be required by the Contract Documents, as specified herein, and as directed by the City Engineer.

K. Bid Item 11 – Remove Tree

1. **Remove Tree** shall be measured by **Each** and paid for in accordance with Article 8 of the General Conditions.
2. The work associated with **Remove Tree** shall include full compensation for furnishing all transportation, labor, materials, tools, equipment, and incidentals necessary to perform all work involved in removing a tree, including but not limited to, removing the existing tree and tree stump; protecting existing irrigation in place; coordination with the property owner to minimize impacts; maintain existing irrigation; landscaping backfill; and complying with the requirements as specified in this section, as described in the Contract Documents, as shown on the plans, as specified herein, and as directed by the City Engineer.

PART 2 - MATERIALS

NOT USED

PART 3 - EXECUTION

PART 4 - PAYMENT

4.1 MEASUREMENT AND PAYMENT

- A. Full compensation for furnishing all transportation, temporary facilities and utilities, labor, materials, tools, equipment, and incidentals necessary to perform all work required to conform to this Section shall be considered as included in the Contract prices paid for the various bid items of work involved and no additional compensation will be allowed.

++ END OF SECTION ++

SECTION 01200 – PROJECT MEETINGS

PART 1 - GENERAL

1.1 PRECONSTRUCTION CONFERENCE

- A. Upon receipt of the Notice to Proceed, or at an earlier time if mutually agreeable, the Engineer will arrange a preconstruction conference to be attended by the Contractor's superintendent or other project representative authorized to commit on the behalf of the Contractor.
- B. The purpose of this conference will be to establish a working relationship and understanding between the parties and to discuss subjects as may be pertinent for the execution of the work
- C. The Contractor shall be prepared to discuss the following subjects, as a minimum:
 - 1. Required schedules.
 - 2. Status of Bonds and Insurance.
 - 3. Sequencing of critical path work items.
 - 4. Progress payment procedure.
 - 5. Project changes and clarifications.
 - 6. Use of site, access, office and storage areas, security and temporary facilities.
 - 7. Major product delivery and priorities.
 - 8. Contractor's safety plan and representative.

1.2 PROGRESS MEETINGS

- A. The City Engineer will arrange and conduct progress meetings. The City Engineer will prepare and circulate a draft agenda of each meeting. The Contractor may add items as appropriate to the draft agenda.
- B. Progress meetings will be conducted on a regular basis, at such frequency as the City Engineer and Contractor may mutually agree. Progress meetings shall be attended by the City Engineer, Operations personnel, Contractor's superintendent or other project representatives, and representatives of all subcontractors involved in the work at the time of the meeting, required by the Contractor, or requested by the City Engineer.
- C. The purpose of the meetings will be to facilitate the work of the Contractor and any subcontractor or other organization that is not up to schedule, resolve conflicts, identify and resolve any potential delays or necessary changes in the work and in general, coordinate and facilitate the execution of the work.
- D. The agenda of progress meetings shall include review of work progress, the latest Construction Schedule submittal (monthly), potential project delays, and the status of

key shop drawings, submittal reviews, information requests, safety concerns, record drawings, and extra work items.

1.3 PROJECT MANAGEMENT DOCUMENTATION AND ADMINISTRATION

- A. The Contractor shall submit the items associated with this section via Virtual Project Manager (VPM), an online cloud-based project management system, as specified in Section 01010 - SUMMARY OF WORK and Section 01300 – SUBMITTAL.

PART 2 - MATERIALS

NOT USED

PART 3 - EXECUTION

NOT USED

PART 4 - PAYMENT

4.1 MEASUREMENT AND PAYMENT

- A. Full compensation for conforming to the requirements of this section shall be considered as included in the prices paid for the various contract items of work involved and no additional compensation will be allowed.

++ END OF SECTION ++

SECTION 01300 – SUBMITTALS

PART 1 - GENERAL

1.1 SCOPE OF WORK

- A. After the notice to proceed is issued, but prior to the start of construction, the Contractor shall submit to the City, for approval, all required permits and verification of the location and depth of all existing utilities and underground facilities within the project limits. The Contractor shall notify the City Engineer of any discrepancies between the conditions in the field and the project plans.
- B. Submittal requirements specified in this section include shop drawings, product data, samples, and miscellaneous work related submittals.
- C. The Contractor shall submit to the City for approval, prior to the start of construction, the following:
 - 1. Emergency Phone Number List
 - 2. Temporary Traffic Control Plan
 - 3. Erosion/Pollution Control Plan
 - 4. Construction Schedule
 - 5. Haul Route Proposal
 - 6. Proof of Agreement for Staging Area
 - 7. Resume of Proposed Project Superintendent
 - 8. Notice to Residents
- D. The Contractor shall submit to the City for approval, prior to beginning any work associated with these submittals, the following:
 - 1. Class 2 Aggregate Base
 - 2. Concrete Mix Design
 - 3. Concrete Cure
 - 4. Detectable Warning Surface
 - 5. Asphalt Concrete
 - 6. Backfill Material

1.2 VIRTUAL PROJECT MANAGER (VPM)

- A. Virtual Project Manager (VPM) allows for paperless documentation and project administration. All posted information is available to all personnel involved with the project at any time using the internet.

- B. The use of VPM by the Contractor is mandatory. Access to VPM will be provided at no cost to the contractor.
- C. In order to utilize VPM, the contractor needs a computer, internet access, a digital camera, and a scanner. For more information, go to www.virtual-pm.com. To Login, from the homepage, select LOGIN and enter the Username and Password that will be provided to you by the agency.
- D. The contractor shall use the following features:
 - 1. Daily Logs: Contractor's daily reports shall be entered electronically via VPM.
 - 2. Payments: Contractor shall enter payment application quantities and submit for review and payment via VPM.
 - 3. Change Order Manager: Contractor requests for change order shall be submitted electronically via VPM.
 - 4. Transmittals: Schedules, Pay applications, etc. shall be submitted electronically via VPM.
 - 5. Submittals: Submittals requiring approval shall be submitted electronically via VPM.
 - 6. RFIs: Requests for information (RFIs) shall be submitted electronically via VPM.

1.3 ENGINEER'S REVIEW:

- A. The City Engineer will have a minimum of ten (10) working days to review each submittal. It is the responsibility of the Contractor to organize submittals in order of importance and need. The Contractor shall submit electronic copies of all submittals; however the City may request hard copies as needed.
- B. The Engineer's review of shop drawings will be general and shall not be construed:
 - 1. As relieving Contractor of responsibility for omissions or errors, including details, dimensions, materials, etc.;
 - 2. That review of a separate item indicates acceptance of an assembly in which the item functions.

1.4 QUALITY ASSURANCE

- A. Each submittal shall have a Certificate of Compliance signed by the manufacturer of the material or the manufacturer of the assembled materials and shall state that the materials involved comply in all respects with the requirements of these technical specifications.
- B. Materials used on the basis of a Certificate of Compliance may be sampled and tested at any time. The fact that material is used on the basis of a Certificate of Compliance shall not relieve the Contractor of the responsibility of incorporating material in the work which conforms to the requirements of the plans and specifications, and any material not conforming to the requirements will be subject to

rejection whether in place or not. The City reserves the right to refuse to permit the use of material on the basis of a Certificate of Compliance.

- C. Materials will be inspected at destination to assure compliance with the specified requirements. Any materials that are found to be defective or that do not meet the requirements of the specifications must be replaced.
- D. The Contractor must schedule the Work to allow time for Quality Assurance Testing.

1.5 SUBMITTAL PROCEDURE

- A. The Contractor shall utilize the agency's online cloud-based project management system (Virtual Project Manager) for submittals.

1.6 HAUL ROUTE APPROVAL

- A. The Contractor shall familiarize himself/herself with the condition of the local streets and roads that may be used for hauling material and equipment to and from the job site. Some existing roads may have inadequate pavement sections to support fully loaded trucks or other heavy equipment.
- B. The proposed haul route shall be submitted prior to the start of construction for review and approval by the City Engineer.

PART 2 - MATERIALS

NOT USED

PART 3 - EXECUTION

3.1 CONTRACTOR'S RESPONSIBILITIES

- A. Provide permanent marking on each submittal to identify Project, date, Contractor, subcontractor, submittal name, and similar information to distinguish it from other submittals.
- B. Each submittal shall be submitted with the cover sheet.
- C. Number all submittals.
- D. Sign and date, with Contractor's review stamp on each sheet of submitted material indicating that submittal is in conformance with Contract Documents
- E. Include sufficient data to permit a detailed study of product or system submitted.
- F. Mark each item submitted with the applicable page and paragraph number of the Specification Section and/or the detail and sheet number of the Contract Drawings.
- G. Include manufacturer's installation instructions and test reports where applicable.
- H. The Contractor shall utilize the agency's online cloud-based project management system (Virtual Project Manager) for submittals.

3.2 ENGINEER'S RESPONSIBILITIES

- A. Engineer's Action: Engineer will review each submittal, mark with "Action" and return within ten (10) calendar days from date of receipt.
- B. Where submittal must be held for coordination with other submittals, Contractor will be so advised without delay.
- C. Action markings shall be interpreted as follows:
 - 1. "No Exception Taken" - Work may proceed, provided it complies with Contract Documents.
 - 2. "Exceptions Noted" - Work may proceed, provided it complies with notations and corrections on submittal and with Contract Documents.
 - 3. "Revise and Resubmit" or "Rejected" - Do not proceed with Work. Revise submittal in accordance with notations thereon, and resubmit without delay to obtain a different action marking
- D. The Engineer will return reviewed submittals electronically via Virtual Project Manager.

PART 4 - PAYMENT

4.1 MEASUREMENT AND PAYMENT

- A. Full compensation for conforming to the requirements of this section shall be considered as included in the prices paid for the various contract items of work involved and no additional compensation will be allowed.

++ END OF SECTION ++

SECTION 01310 – CONSTRUCTION SCHEDULE

PART 1 - GENERAL

1.1 SCOPE OF WORK

- A. The work specified in this Section includes the Contractor's preparation, submittal, maintenance and use of a computerized Critical Path Method (CPM) Construction Schedule to plan and monitor construction progress for the project.
- B. The computerized CPM schedule shall be completed using Microsoft Project for Windows or another software package acceptable to the Engineer.
- C. The requirements specified under Section 01300, Submittals, also apply to the Construction Schedule initial submittal(s) and subsequent updates and revisions
- D. The ADA curb ramps shall be completed before any other work commences.

1.2 PREPARATION AND SUBMITTAL PROCEDURE

- A. The Contractor's on-site construction supervisor (superintendent, project manager, etc.) shall be directly involved in preparation of the Construction Schedule.
- B. The Construction Schedule shall be completed and submitted to the Engineer within 30 days after Notice to Proceed.
- C. By preparing and submitting the Construction Schedule the Contractor represents that the Contractor can and intends to execute the work and portions thereof within the specified times and constraints and that the Contractor's bid covers the costs associated with the execution of work in accordance with the Construction Schedule.
- D. At the time of submittal of the Construction Schedule, Contractor's on-site construction supervisor shall review the schedule with Engineer's construction project representative.
- E. If the initial Construction Schedule submittal is not acceptable to the Engineer, it shall be revised in coordination with observations and comments from the Engineer and resubmitted within 7 days of the return of the schedule to the Contractor.

1.3 CONSTRUCTION SCHEDULE REVIEW

- A. The Construction Schedule will be reviewed monthly during an agreed upon progress meeting to verify at a minimum:
 - 1. Actual start and finish dates of completed activities since the last progress meeting.
 - 2. Durations and progress of all activities not completed.
 - 3. Critical submittals/materials delivery problems.
 - 4. Potential project delays.
 - 5. Any activity behind schedule and Contractor's plan to bring it back on schedule.

- B. Reason, logic, time, and cost data for Change Order work that is to be incorporated into the Construction Schedule or payment request form.
- C. Payment due to the Contractor based on percentage complete of items in the submittal payment request form

1.4 CITY TRUCKS AND BUSES

- A. Contractor shall schedule construction operations such that trash pickup services are not interrupted or affected. Contractor shall coordinate with the Disposal Company/City of Brentwood to prevent any conflicts or interruptions in trash pickup services.
- B. The Contractor shall not impede or impair waste haulers, recycling operations and buses within the project area. It is the Contractor's responsibility to determine which waste haulers, recycling operators and buses are scheduled to work/run in the project area and to develop a project schedule that will not impede or impair their operations.

PART 2 - MATERIALS

NOT USED

PART 3 - EXECUTION

NOT USED

PART 4 - PAYMENT

4.1 MEASUREMENT AND PAYMENT

- A. Full compensation for conforming to the requirements of this section shall be considered as included in the prices paid for the various contract items of work involved and no additional compensation will be allowed.

++ END OF SECTION ++

SECTION 01500 – ADJACENT PROPERTY OWNERS

PART 1 - GENERAL

1.1 ADJACAENT PROPERTY OWNERS

- A. The Contractor shall give written notice seven (7) calendar days in advance of construction to notify all property owners and their tenants indicating the date(s) of construction within or adjacent to their property. Property owners shall also be notified of fences, mailboxes, etc., that will be temporarily removed for construction or relocated. The Contractor shall submit to the City Engineer a sample letter of notification for approval three (3) working days prior to distribution to property owners. The Contractor may obtain a list of property owners and their addresses from the City of Brentwood.
- B. The Contractor shall provide for continuous vehicular and pedestrian ingress and egress to private properties and residential/commercial driveways adjacent to work through the period of construction. The Contractor's attention is directed to Section TS-3, "Obstructions and Other Utility's Work", of these Contract Documents pertaining to preservation of property and Contractor's responsibility for damage.

1.2 SOUND CONTROL REQUIREMENTS

- A. Sound control shall conform to the provisions in City Municipal Code, Section 9.32.030 "Designated Noise Zones".
- B. The noise level from the Contractor's operations, between the hours of 7:00 a.m. to 10:00 p.m. (if this time period is approved by the City Engineer), shall not exceed 60 dBA exterior noise level. From 10:00 p.m. to 7:00 a.m. (if this time period is approved by the City Engineer), shall not exceed 45 dBA exterior noise level.
- C. The noise level requirement shall apply to the equipment on the job or related to the job, including but not limited to trucks, transit mixers or transient equipment that may or may not be owned by the Contractor. The use of loud sound signals shall be avoided in favor of light warnings except those required by safety laws for the protection of personnel.
- D. Construction activities resulting in noise levels exceeding the non-construction ambient noise (e.g., jackhammer, sawcutting, etc.) shall be prohibited within 100 feet of any restaurant and cafes during the weekday lunch hour from 11:59 AM to 1:00 PM.

1.3 LIMITS OF WORK

- A. The street right of way shall be used only for purposes that are necessary to perform the required work. The Contractor shall not occupy the right of way for purposes which are not necessary to perform the required work.
- B. Areas available for the use of the Contractor are designated on the plans by easement or right of way lines. Use of the Contractor's work areas and other City-owned property shall be at the Contractor's own risk, and the City shall not be held liable for any damage to or loss of materials or equipment located within such areas.

- C. The Contractor shall remove all equipment, materials, and rubbish from the work areas and other City-owned property which the Contractor occupies and shall leave the areas in a presentable condition, in accordance with the provisions in Section 4-1.13, "Cleanup," of the Caltrans Standard Specifications.
- D. The Contractor shall secure at his own expense any area required for plant sites, storage of equipment or materials, or for other purposes if sufficient area is not available to him within the contract limits, or at the sites designated on the plans outside the contract limits.
- E. In the areas of City right of way not designated for the exclusive use by the Contractor, the Contractor shall coordinate with adjacent project and property owners to ensure that storage of materials will not restrict access for those projects or properties. If stored materials must be relocated to provide access, the Contractor shall relocate the stored material at his own expense and no claim for costs to relocate the stored materials will be allowed.
- F. The Contractor shall limit his operations to the areas within the existing City right-of-way or in areas the City has acquired a temporary construction easement. Where the specific limits of work are not designated on the plans or specified in these Specifications, the Contractor shall limit his operation to the existing road rights of way.
- G. All existing structures, residences, operating utilities, power poles, and other devices within the work area shall be maintained at all times during construction.

1.4 USE OF OWNER'S FACILITIES

- A. The Contractor may use existing facilities or equipment in the Work for construction purposes, only if the Owner's written permission is obtained.
- B. Restore existing facilities and equipment to original condition in a manner satisfactory to the Owner.

PART 2 - PRODUCTS

NOT USED

PART 3 - EXECUTION

3.1 NOTICE TO AFFECTED PARTIES

- A. At ten (10) working days and again at two (2) working days prior to mobilizing to a site or performing any action which affects residents, schools or businesses, the Contractor shall distribute an approved written, "door hanger" type notice to all adjoining residents and businesses, property owners, tenants and applicable parties. Such notice shall state that all vehicles and equipment need to be moved off of the street and include the expected date for start of construction, a general description of the construction activity to take place, expected duration of the activity, traffic delays, alternative routes, driveway closures and the name, address, and a 24-hour local telephone number of the Contractor. The Contractor shall check for messages hourly from 7:00 a.m. to 6:00 p.m. and at least once every twelve (12) hours during nights, weekends and holidays. The Contractor shall respond promptly to all messages.

- B. A draft copy of the notice shall be provided to the City Engineer for approval, prior to distribution. The Contractor shall notify all residents and businesses within at least 300 feet of the work. It is the Contractor's responsibility to keep all affected residents, schools and businesses notified of the work and work schedule, and to provide whatever facilities are necessary to assure the minimum possible inconvenience to their lives and operations.
- C. The Contractor shall provide the City Engineer a copy of the proposed written notification prior to mailing or delivery for approval at least five (5) days prior to their distribution. The Contractor shall provide a copy of the written notification as mailed or delivered, as well as a list of all recipients of such notifications. The Contractor shall maintain an updated and chronological record at the job site of all written notifications along with a list of recipients. Such records shall be made available to the engineer upon request. All information shall be submitted to the City Engineer for inclusion on the City of Brentwood Web Page.
- D. Five (5) working days prior to construction activities, the following parties shall also be notified:

Brentwood Union School District
Phone: (925) 513-4113
255 Guthrie Lane
Brentwood, CA 94513

Tri Delta Transit
Phone: (925) 754-6622
801 Wilbur Avenue
Antioch, CA 94509

Postal Service
Phone: 1 (800) 275-8777
18 Oak St
Brentwood, CA 94513-9998

Police Department
Phone: (925) 634-6911 (Main Number)
Dispatch (24 hrs) (925) 809-7911 (Non-Emergency)
9100 Brentwood Blvd.
Brentwood, CA 94513

Liberty Union School District
Phone: (925) 634-2166 x 2032
20 Oak Street
Brentwood, CA 94513

Contra Costa County Fire Protection District
Phone: (925) 941-3300
4005 Port Chicago Highway, Suite 250
Concord, CA 94520-1180

Disposal Company/City of Brentwood
Contact: Jon Carlson
Phone: (925) 516-6095
2301 Elkins Way
Brentwood, CA 94513

Chamber of Commerce
Phone: (925) 634-3344
35 Oak Street
Brentwood, CA 94513

- E. Delays in performing the work or changes in the construction schedule, for any reason, shall require the Contractor to provide written re-notification to residents, businesses, City services and the local newspaper within 24 hours that any delay or change is reported to or discovered by the City Engineer. If the local paper publishes an incorrect schedule, The Contractor shall re-publish the correct schedule to run the following two (2) consecutive days.
- F. Failure to properly notify residents will necessitate the Contractor to reschedule his work with no additional working days to be added to the Contract and additional liquidated damages applied.

PART 4 - PAYMENT

4.1 MEASUREMENT AND PAYMENT

- A. Full compensation for conforming to the requirements of this section shall be considered as included in the prices paid for the various contract items of work involved and no additional compensation will be allowed.

++ END OF SECTION ++

SECTION 01505 – MOBILIZATION

PART 1 - GENERAL

1.1 SPECIFICATIONS

- A. Mobilization shall conform to the applicable provisions in Section 9-1.16D, "Mobilization", of the Caltrans Standard Specifications.

1.2 SCOPE OF WORK

- A. Mobilization shall consist of preparatory work and operations, including but not limited to those necessary for the movement of personnel, equipment, supplies, and incidentals to the project site, including administration, overhead, bonds, insurance and incidentals; for the establishment of all facilities necessary for work on the project; and for all other work and operations which must be performed or costs incurred prior to beginning work on the various Contract items on the project site. Mobilization shall include de-mobilization of equipment and personnel upon completion of construction.

PART 2 - MATERIALS

NOT USED

PART 3 - EXECUTION

3.1 STAGING

- A. The Contractor shall prepare a detailed Stage Construction Plan and submit it to the City for Approval.
- B. The Contractor shall not use any private driveways or property to turn around or for temporary stockpile of material or staging areas unless written permission is obtained from the property owner by the Contractor.
- C. The Contractor shall survey the area for construction staging point locations and shall negotiate the use of private property with the property owner. The Contractor shall show proof of an agreement prior to using any private property for a staging area and the City shall approve the conditions of the agreement. No staging or storage of materials will be allowed on the public right of way unless specifically requested by the Contractor and approved in writing by the City Engineer.
- D. The Contractor shall prepare a Staging Plan that includes every phase of construction. The Staging Plan shall be submitted to the City Engineer within 10 days of the Notice to Proceed. Work shall not proceed without the City Engineer's advance approval of the Staging Plan.
- E. The staging plan needs to consider the locations of schools and other facilities that have high volumes of traffic that will be affected by the construction. The Contractor shall schedule his operations to minimize the impact on traffic.
- F. Upon completion of the project or as specified in the staging agreement and plan, the Contractor shall clean the site and return the site to its original condition. The Contractor shall replace with like materials any improvement damaged by the

Contractor's staging operations. Should the Contractor fail to perform these duties, the City Engineer, at the City Engineer's sole discretion, may elect to have City, or contract forces, perform the duties, deducting the expenses incurred from any moneys that are due, or become due, to the Contractor. By exercising this option, the Contractor is in no way relieved of the responsibility to perform these duties.

PART 4 - PAYMENT

4.1 MEASUREMENT AND PAYMENT

- A. **Mobilization** shall be measured by **lump sum** and paid for in accordance with Article 8 of the General Conditions and Section 01015 – SUMMARY OF BID ITEMS.

++ END OF SECTION ++

SECTION 01600 – STORM WATER EROSION/POLLUTION CONTROL

PART 1 - GENERAL

1.1 SCOPE OF WORK

- A. The Contractor is required to prepare an Storm Water Erosion/Pollution Control Plan and implement the plan once approved by the Engineer.
- B. The intent of these requirements is to enforce federal, state and local laws, ordinances, codes and regulations that pertain to storm water pollution attributable to construction projects. Storm drains discharge directly to creeks without treatment. Therefore, discharge of pollutants (i.e. any substance, material or waste other than uncontaminated storm water) into the storm drain system is strictly prohibited.
- C. For the purpose of eliminating storm water pollution, the Contractor shall implement effective control measures over the entire project. There are several publications which provide guidance on selecting and implementing effective control measures known as Best Management Practices (BMPs). BMPs include, but are not limited to, schedules of activities, prohibition of practices, general good housekeeping practices, operational practices, pollution prevention practices, maintenance procedures and other management procedures designed to prevent the discharge of pollutants directly or indirectly to the storm drain system. BMPs also include the construction of some facilities which may be required to prevent, control and abate storm water pollution. The reference publications are as follows:
 - 1. California Storm Water Best Management Practices Handbook - Industrial/Commercial
 - 2. California Storm Water Best Management Practices Handbook - Construction Activity
- D. The Contractor must comply with the State of California's General Permit for Stormwater Discharges associated with construction activities (order no. 2009-0009-DWQ).

PART 2 - MATERIALS

2.1 MATERIALS

- A. All materials used for Best Management Practices (BMPs) shall be featured in the Storm Water Erosion/Pollution Control Plan and shall be acceptable methods of storm water management and pollution control.

2.2 MATERIAL STORAGE

- A. Storage and exposure of raw materials, by-products, finished products, and containers shall be controlled as described below:
 - 1. All construction materials shall be stored at least ten (10) feet away from inlets, catch basins, and curb returns. The Contractor shall not allow any material to enter the storm drain system. At the end of each working day, the Contractor shall collect and dispose of all scrap, debris, and waste material.

2. During wet weather or when rain is forecast, the Contractor shall store materials that can contaminate rainwater or be transported by storm water or other runoff to the storm drain system inside a building or cover them with a tarp or other waterproof material secured with weighted tires or sandbags to prevent contact with rain.
- B. The Contractor is reminded that storage and disposal of all hazardous materials such as paints, thinners, solvents, and fuels; and all hazardous wastes such as waste oil must meet all federal, state and local standards and requirements.

PART 3 - EXECUTION

3.1 DE-WATERING OPERATIONS

- A. All groundwater removed from the trench or excavations must be removed and disposed of off-site in accordance with local and state requirements and through methods and procedures described in the California Storm Water Best Management Practice Handbook - Construction Activity (latest edition). A sampling and analysis program for non-visible storm water pollutants must be implemented if required. Sampling & analysis guidance can be found in the Fact Sheet of the National Pollutant Discharge Elimination System (NPDES) General Permit for Discharge of Storm Water associated with construction activities Order No. 99-08-DWQ (8/27/04) from the following link:

http://www.waterboards.ca.gov/water_issues/programs/stormwater/docs/finalconstpermit.pdf

- B. If there is suspicion of soil amendments (such as lime, fly ash, etc.) are being used and they will be exposed to storm water, a sampling and analysis program must be implemented.

3.2 PAVEMENT SAW-CUTTING OPERATIONS

- A. The Contractor shall prevent any saw-cutting debris from entering the storm drain system. The Contractor, preferably, shall use dry cutting techniques and sweep up residue. If wet methods are used, the Contractor shall vacuum slurry as cutting proceeds or collect all wastewater by constructing a sand bag sediment barrier. The bermed area shall be of adequate size to collect all wastewater and solids. The Contractor shall allow collected water to evaporate if the wastewater volume is minimal and if maintaining the ponding area does not interfere with public use of the street area or create a safety hazard. If approved by the City Engineer, the Contractor may direct or pump saw-cutting wastewater to a dirt area and allow to infiltrate. The dirt area shall be adequate to contain all the wastewater. After wastewater has infiltrated, all remaining saw-cutting residue must be removed and disposed of properly. Remaining silt and debris from the ponding or bermed area shall be removed or vacuumed and disposed of properly.
- B. If a suitable dirt area is not available or discharge to the sanitary sewer is not feasible, with the approval of the City Engineer and Contra Costa County Flood Control (CCCFC) & Water Conservation District (WCD), the Contractor shall filter the saw-cutting wastewater through filtering materials and methods meeting ABAG Standards for Erosion and Sedimentation Control Measures (latest edition) before discharging to the storm drain.

3.3 PAVEMENT OPERATIONS

A. The Contractor shall prevent the discharge of pollutants from paving operations by using measures to prevent run-on and run-off pollution, disposing of wastes properly, and by implementing the procedures in the Best Management Practices Handbook. In addition, the Contractor shall observe the following guidelines:

1. Paving during wet weather:
 - a. No paving while it is raining.
 - b. No paving of the top lift of asphalt concrete (AC) on any day that experiences $\frac{1}{4}$ " of rain in a twenty-four (24) hour period.
 - c. No paving of bottom lift if previous seventy-two (72) hour period experienced more than $\frac{1}{2}$ " rain, unless directed by the City Engineer or his designee.

B. Store materials as required under this section.

1. Cover inlets and manholes when applying asphalt, seal coat, tack coat, slurry seal, fog seal, etc.
2. Place drip pans or absorbent materials under paving equipment when not in use. During wet weather, store contaminated paving equipment indoors, or cover with tarp or other waterproof covering.
3. Sweep site daily using mechanical methods to prevent sand, gravel or excess asphalt from entering or being transported by rain into the storm drain system.
4. Keep ample supplies of drip pans or absorbent materials on-site.
5. If paving involves Portland cement concrete, refer to section F below.

C. All of the above is at the discretion of the City Engineer or his designee.

3.4 CONCRETE OPERATIONS

A. **Do not wash out concrete trucks into storm drains, open ditches, streets, streams, etc.** The Contractor shall prevent the discharge of pollutants from concrete operations by using measures to prevent run-on and run-off pollution, properly disposing of wastes, and by implementing the following BMPs:

1. Store all materials in waterproof containers or under cover away from drain inlets or drainage areas.
2. Avoid mixing excess amounts of Portland cement materials. Dispose of any excess materials properly.
3. Whenever possible, perform washout of concrete trucks off-site where discharge is controlled and not permitted to discharge to the storm drain system. For on-site washout:
4. Locate washout area at least fifty feet from storm drains, open ditches or other water bodies, preferably in a dirt area. Confine run-off from this area by

constructing a temporary pit or bermed area large enough for the liquid and solid waste.

5. Wash out concrete wastes into the temporary pit where the concrete can set, be broken up and then disposed of properly. If the volume of water is greater than what will allow concrete to set, allow the wash water to infiltrate and/or evaporate, if possible. Remove or vacuum the remaining silt and debris from the ponding or bermed area and dispose of it properly.
6. Dispose of wastewater from washing of exposed aggregate to dirt area. The dirt area shall be adequate to contain all the wastewater and once the wastewater has infiltrated, any remaining residue must be removed.
7. Collect and return sweepings from exposed aggregate concrete to a stockpile or dispose of the waste in trash container.

3.5 GRADING AND EXCAVATION OPERATIONS

- A. The erosion and sedimentation control materials and methods shall be in accordance with ABAG Standards for Erosion and Sediment Control Measures and/or the procedures and methods described in the California Storm Water Best Management Practice Handbook - Construction Activity (latest edition) and the City of Brentwood's grading ordinance.
- B. Sedimentation and erosion control/filter materials shall be placed in a manner that will retain any debris or sediment from flowing into the storm drain system. The Contractor shall have labor, tools, equipment and materials needed, at the job site, to provide the erosion control measures necessary as a result of earthwork or trenching before beginning or continuing these construction activities. Sand bags and straw wattle shall be stockpiled adjacent to the locations of activity and ready to be installed when the rainfall forecast for 48 hours is 40% or greater or when directed by the City Engineer.
- C. The Contractor shall install siltation control devices around catch basins prior to starting construction. These devices shall be maintained at all times during the construction period, and shall be removed when construction is complete.
- D. The Contractor shall not be allowed to block existing drainage flowing onto the work area. The Contractor shall install temporary drainage facilities, if necessary. There shall be no extra compensation to the Contractor for keeping existing drainage open. The Contractor is responsible for any damage to property or existing improvements resulting from blocking existing drainage.
- E. The Contractor shall inspect the sites of work at the beginning and once every 24-hour period through the duration of each storm to assure that inlets and pipes are not blocked with silt or debris and shall be prepared to make repairs to the erosion control devices and take any other remedial measures as directed by the City Engineer. At the end of a storm event all depressions with ponded water, the water in catch basins, and the check dam ponds shall be pumped dry and all silt and debris removed. This work shall be completed within twenty-four (24) hours after the end of each storm.

3.6 SPILL PREVENTION AND CONTROL

- A. The Contractor shall take any and all precautions to prevent accidental spills during the work under this contract. However, in the event of a spill:
 - 1. The Contractor shall immediately contain and prevent leaks and spills from entering the storm drain system, and properly clean-up and dispose of the waste and clean-up materials. If waste is hazardous, the Contractor shall comply with all federal, state and local hazardous waste requirements. All work vehicles should be equipped with spill response kits.
 - 2. The Contractor shall not wash any spilled material into the streets, gutters, storm drains, or creeks.
 - 3. The Contractor shall report any hazardous material spills immediately to the City Engineer and the City of Brentwood Police Department, as per hazardous material response protocol.

3.7 VEHICLE/EQUIPMENT CLEANING

- A. The Contractor shall not perform vehicle or equipment cleaning or maintenance on-site or in the street using soaps, solvents, de-greasers, steam cleaning equipment or equivalent methods. The Contractor shall perform vehicle or equipment cleaning with water only in a designated, bermed area that will not allow rinse water to run off-site or into the storm drain system. The rinse-water shall be permitted to infiltrate in dirt area or shall be discharged to the sanitary sewer with the approval of the City Engineer.
- B. The Contractor shall dispose of wash water from the cleaning of water base paint equipment and tools to the sanitary sewer.
- C. If using oil based paint, to the maximum extent practicable, the Contractor shall filter the paint thinner and solvents for reuse and dispose of the waste thinner and solvent, and sludge from cleaning of equipment and tools as hazardous waste. No disposal of oil base materials is allowed into the City sewer system.

3.8 CONTRACTOR TRAINING AND AWARENESS

- A. The Contractor shall train all employees on the Storm Water Erosion/Pollution Control requirements contained in these specifications. The Contractor shall inform all subcontractors of the Storm Water Erosion/Pollution Control requirements and include appropriate subcontract provisions to ensure these requirements are met.
- B. The Contractor shall comply with City of Brentwood Standard Specification SD-15c as the work relates to labeling of inlets, all cost associated with the labeling of inlets shall be considered as included in the various bid items of work on this project and no additional compensation will be allowed.

3.9 GOOD HOUSEKEEPING PRACTICES

- A. In addition to the practices and procedures discussed above, the Contractor shall implement the following applicable good housekeeping practices.
 - 1. Store materials that have the potential to be transported to the storm drain system by storm run-off or by a spill under cover in a contained area or in sealed waterproof containers.

2. Use tarps on the ground to collect fallen debris or splatters that could contribute to storm water pollution.
3. Secure opened bags of cement, and other light or powdered materials which can be transported by wind.
4. Pick up litter, construction debris and other wastes daily from outside areas including the sidewalk area, gutter, street pavement and storm drains impacted by the project. All wastes shall be stored in covered containers or disposed of or recycled immediately.
5. Dispose of wash water to the sanitary sewer with the approval of City Engineer or recycle wash water.
6. Inspect vehicles and equipment arriving on-site for leaking fluids and promptly repair leaking vehicles and equipment. Vehicles leaking fluids will not be allowed on the construction site and if not repaired, must be removed.
7. Avoid spills by handling materials carefully. Keep a stockpile of spill control materials, such as rags or absorbents, readily accessible on-site. Clean up all spills immediately to prevent any material from being discharged to the storm drain.
8. Train employees regularly on good housekeeping practices and BMPs. Assign responsibility to specific employees on BMPs, good housekeeping practices, and what to do in the event of a spill.
9. Maintain and replace all sediment and water pollution control devices as necessary to ensure that said controls are working effectively (e.g. inspect all sediment ponds or filtering systems after each rain. Remove accumulated sediment and debris and replace or repair damaged sandbags immediately).

PART 4 - PAYMENT

4.1 MEASUREMENT AND PAYMENT

- A. **Storm Water Erosion/Pollution Control** shall be measured by **lump sum** and paid for in accordance with Article 8 of the General Conditions and Section 01015 – SUMMARY OF BID ITEMS.

+ END OF SECTION ++

SECTION 01650 – DUST CONTROL

PART 1 - GENERAL

1.1 SCOPE OF WORK

- A. Dust control shall conform to the provisions in Section 10-5 and 14-11.04, "Dust Control," of the Caltrans Standard Specifications and these Specifications.
- B. The Contractor will be responsible for preventing airborne dust nuisance from the construction site by watering and/or treating the site in such a manner to confine dust particles to the immediate surface of work.
- C. Watering shall conform to the Provisions in Section 10-6, "Watering," of the Caltrans Standard Specifications and these Specifications.

PART 2 - MATERIALS

2.1 WATERING

- A. Water for construction purposes (with the exception of water to be used for the waterline testing, as specified in the Standard Specifications), shall be non-potable water and shall be the responsibility of the Contractor. The Contractor shall make arrangements for obtaining and purchasing water for construction of the project. The City cannot guarantee the availability of construction water for this project. The Contractor will be required to obtain water through his/her own means if water is not available through the City, at his/her own expense at no additional cost to the City.

2.2 DUST PALLIATIVE

- A. Furnishing and applying dust palliative shall conform to the provisions in Section 18, "Dust Palliatives," of the Caltrans Standard Specifications.

PART 3 - EXECUTION

3.1 DUST CONTROL

- A. When necessary or when directed by the Engineer, the Contractor shall apply water for laying dust. Water shall be applied by means of pressure- type distributors equipped with a spray system that will insure a uniform application. The Contractor shall provide and operate a portable water vehicle to deliver water for construction and materials such as aggregate base rock, for equipment and general airborne dust control. The Contractor shall be continuously prepared throughout the course of the project to immediately mitigate airborne dust nuisance.

PART 4 - PAYMENT

4.1 MEASUREMENT AND PAYMENT

- A. Full compensation for conforming to the requirements of this section shall be considered as included in the prices paid for the various contract items of work involved and no additional compensation will be allowed.

++ END OF SECTION ++

SECTION 01700 – EXISTING FACILITIES

PART 1 - GENERAL

1.1 SPECIFICATIONS

- A. Existing Facilities shall conform to Section 7.12 “Existing Utilities” of the General Conditions and Section 5-1.36 "Property and Facility Preservation", Section 7-1.05 “Indemnification”, Section 7-1.06, “Insurance”, and Section 15, "Existing Facilities," of the Caltrans Standard Specifications.
- B. Nothing in these Specifications shall relieve the Contractor from his/her responsibility in conformance with the provisions in Section 7-1.04, “Public Safety,” of the Caltrans Standard Specifications.

1.2 SCOPE OF WORK

- A. Existing facilities above and below ground that are not designated to be removed shall be protected from injury or damage. The Contractor, if ordered by the City Engineer, shall provide and install suitable safeguards, approved by the City Engineer, to protect such objects from injury or damage. If such objects are injured, damaged, or removed by reason of the Contractor's operations, they shall be immediately replaced or restored to the satisfaction of the City Engineer at the Contractor's expense.
- B. It is not the intent of the plans to show the exact location of existing or relocated utilities, and the Engineer assumes no responsibility therefor. Whenever such utilities are indicated thereon, the Contractor shall be responsible for verifying their actual location and depth in the field.
 - 1. The Project Plans only show existing facilities managed by The City of Brentwood. It is the responsibility of the Contractor to verify existing facilities that are not owned by the City of Brentwood (ex. PG&E, Comcast, AT&T, etc.).
- C. If the Contractor learns of the existence or location of any underground utility omitted from or shown incorrectly on the Plans or not properly marked, the Contractor shall immediately notify the Engineer. The fact that any underground facility is not shown upon the plans shall not relieve the Contractor of his responsibility under Section 5-1.36D, “Non-Highway Facilities” of the Caltrans Standard Specifications. It shall be the Contractor's responsibility, pursuant thereto, to ascertain the location of such underground improvements or facilities which may be subject to damage by the construction operations.

1.3 EXISTING UTILITIES

- A. The Contractor shall notify the City Engineer and the appropriate regional notification center for operators of subsurface installations at least 2 working days, but not more than 14 calendar days, prior to performing any excavation or other work close to any underground pipeline, conduit, duct, wire or other structure. Regional notification centers include but are not limited to the following:

Notification Center	Telephone Number
USA North 811	1-800-642-2444

- B. If such facilities are not located on the plans in both alignment and elevation, no work shall be performed in the vicinity of said facilities until the owner, or representative, has located the facility by potholing, probing, or other means that will locate and identify the facility.
- C. The Contractor's attention is directed to the existence of certain underground facilities that may require special precautions be taken by the Contractor to protect the health, safety and welfare of workmen and of the public. Facilities requiring special precautions include, but are not limited to: conductors of petroleum products, oxygen, chlorine, and toxic or flammable gases; natural gas in pipelines greater than 6 inches in diameter or pipelines operating at pressures greater than 60 psi gauge; underground electric supply system conductors or cables, with potential to ground of more than 300 volts, either directly buried or in duct or conduit which do not have concentric grounded conductors or other effectively grounded metal shields or sheaths.
- D. The Contractor shall cooperate completely with all utility companies having facilities within the project area. Any delay caused by the utility companies in completion of their work will not entitle the Contractor to additional compensation.
- E. This project includes work on streets with overhead utility and service lines. In some locations, these utility and service lines may have minimal vertical clear distance or clearance above the existing elevations within the limits of work. It is the Contractor's responsibility to conduct operations around the facilities such that the work is accomplished without damage to these facilities. The Contractor shall notify each utility owner at least two (2) working days prior to the planned work operation around these overhead facilities, and shall satisfy all requirements and safety standards for working in close proximity to these utility and service lines, as required.

1.4 EXISTING UTILITIES CONTACTS

- A. The following utilities may have facilities within the Project area:

Pacific Gas and Electric

Contact: Rex Meneses (925) 779-7783
 Delta District
 2111 Hillcrest Avenue
 Antioch, CA 94509

AT&T (Telephone) - Construction

Contact: Gregory Greenwood (925) 548-4658
 2600 Camino Ramon
 San Ramon, CA 94583

Comcast (Cable)

Contact: Ryan Lawrie (925) 349-3481
 Alt. Contact: Mr. Chad Clark (Sefnco) (925) 280-4386
 2500 Bates Ave.
 Concord, CA 94520

Sonic

Contact: Brian Botteri (707) 522-1000 ext 2369
 2260 Apollo Way
 Santa Rosa, CA 95407

Cablecom, Inc

Contact: Ben Greenwood (925) 370-3021
Alt. Contact: Roderick Ford (Sefnco) (925) 337-2704
825 Chadbourne Road
Fairfield, CA 94534

East Contra Costa Irrigation District

Contact: Pat Corey (925) 634-5951
626 First Street
Brentwood, CA 94513

Contra Costa County Traffic Signal Maintenance

Contact: Traffic Signal Maint. Division (925) 313-7052
2467 Waterbird Way
Martinez, CA 94553

City of Brentwood – Water, Drainage, Sewer, Solid Waste, Fiber Optic, Traffic Signal, Loops, Signal Interconnect and Irrigation.

Contact: Public Works Department (925) 516-6000
2201 Elkins Way
Brentwood, CA 94513

1.5 EXISTING TREES

- A. Attention is directed to Section 5-1.36, "Property and Facility Preservation" of the Caltrans Standard Specifications.
- B. This project includes work on streets with mature trees adjacent to the roadway and sidewalk. In some locations, the tree canopy may extend over the roadway. It is the responsibility of the Contractor to conduct construction operations around said tree canopy such that the work is accomplished without damaging or injuring tree or tree limbs in any way. If existing trees or shrubs encroach into the public right-of-way and threaten to obstruct the Contractor's operations, the Contractor shall request permission to trim existing trees or shrubs, at least five (5) working days prior to the date of scheduled tree trimming. All tree and shrub trimming must have prior approval of the City Engineer and shall be performed by a Contractor possessing a C-27 or C-61 license.
- C. A special notice pertaining to the tree trimming shall be delivered to the adjacent home or business at least two working days before the tree is trimmed. The notice shall be reviewed and approved by the City Engineer before delivery.
- D. When permitted by the City Engineer, tree pruning shall be performed by a Certified Arborist and in accordance with "Pruning Standards," published by the Western Chapter of the International Society of Arboriculture. The Arborist can be a person in the employment of the Contractor as long as the person has been certified by the Western Chapter of the International Society of Arboriculture. The Certified Arborist shall be approved in advance by the City Engineer, and all pruning shall be done in the presence of the City Engineer.

1.6 ROOT CUTTING

- A. The contractor shall notify the City Inspector of any root (over 2 inches) that needs to be cut. The City Inspector will inspect and document the root within 24 hours of the notification. The root cannot be damaged until approval from the City Inspector.

1.7 EXISTING DETECTOR LOOPS

- A. The work performed in connection with Existing Detector Loops shall conform to Section 15, "Existing Facilities" of the Caltrans Standard Specifications and these Technical Provisions. At least two (2) working days prior to any planned work operation involving any roadway surface damage or removal, including cold planing, wedge grinding, or any other destructive work in the vicinity of any signalized intersection, the Contractor shall notify Underground Service Alert (USA).
- B. Existing loops to remain in place.
 - 1. The Contractor shall make every effort to protect the existing traffic signal inductive loop conductors that are to remain in place. If these detector loops are damaged or become inoperative, the Contractor shall notify the City Engineer immediately and the Contractor must replace the loops before the end of the working period, unless otherwise directed by the City Engineer.
 - 2. If any part of the loop conductor, including the portion leading to the adjacent pull box, is damaged by the Contractor's operations, the entire detector loop shall be replaced at the Contractor's expense. If any adjacent loop is damaged during replacement, that loop shall also be replaced at the Contractor's expense and in conformance with City Standards.
- C. Existing loops to be removed and/or replaced.
 - 1. At locations where detector loops are to be removed and/or replaced the Contractor shall notify the City Engineer at least two (2) working days in advance of the detector loop removal operation. The loops to be replaced as indicated on the Plans and in these Technical Specifications shall be done in conformance with City Standards and the provisions of the Technical Specification Section, "Traffic Signal Detector Loops." The detector loops shall be replaced within 48 hours of being disturbed, damaged, removed, or becoming inoperative.

1.8 EXISTING TRAFFIC STRIPING, MARKINGS, AND MARKERS

- A. The Contractors' attention is directed to Section 5-1.36, "Property and Facility Preservation" of the Caltrans Standard Specifications. Existing traffic stripes, pavement markings and pavement markers that are outside the areas of the asphalt concrete pavement overlay and/or slurry seal that are to remain in place shall be protected from wheel marks and other damage by the Contractor. Damaged traffic stripes, pavement markings and pavement markers shall be cleaned or replaced as approved by the City Engineer. The restoration of such objects will be at the Contractor's expense and in conformance with City Standards and the provisions in the Section "Traffic Stripes and Pavement Markings (Thermoplastic)" and Section "Pavement Markers", of these Technical Specifications.

1.9 EXISTING SIGNS TO BE RELOCATED

- A. Street Lights and Street Signs may require resetting or reconstruction as a result of the project improvements as indicated on the plans and as directed by the City Engineer.

1.10 REMOVAL OF USA MARKINGS

- A. The Contractor is responsible to remove all USA Markings that are related to the Contractor's USA tickets.

PART 2 - **MATERIALS**

NOT USED

PART 3 - **EXECUTION**

3.1 Backfill of Potholes

- A. Contractor shall be prepared with construction grade sand to place over found utilities as directed by Engineer, in addition to 2- sack concrete slurry in adequate amounts to reach pavement grade.

PART 4 - **PAYMENT**

4.1 MEASUREMENT AND PAYMENT

- A. Full compensation for conforming to the requirements of this section shall be considered as included in the prices paid for the various contract items of work involved and no additional compensation will be allowed.
- B. Any delays to the Contractor's operations as a direct result of utility or other non-highway facilities not being arranged due to a strike or labor dispute shall entitle the Contractor to an extension of time as provided in Section 8- 1.07B, "Time Adjustments" of the Standard Specifications. The Contractor shall be entitled to no other compensation for that delay.
- C. Any delay caused by the utility companies in completion of their work will not entitle the Contractor to additional compensation.

++ END OF SECTION ++

SECTION 01800 – TRAFFIC AND ACCESS CONTROL

PART 1 - GENERAL

1.1 SPECIFICATIONS

- A. Traffic and access control shall conform to California Manual on Uniform Traffic Control Devices (CA MUTCD), Sections 7-1.03 "Public Convenience," 7-1.04 "Public Safety," and Section 12 "Temporary Traffic Control" of the Caltrans Standard Specifications, and these Specifications. Nothing in these Technical Specifications shall be construed as relieving the Contractor from the responsibilities specified in Caltrans Standard Specifications Section 7-1.04 "Public Safety".

1.2 SCOPE OF WORK

- A. A minimum of five (5) working days prior to the pre-construction meeting, the Contractor shall submit for the Engineer's approval, a traffic control plan for the routing of traffic during construction, including the location of advance warning signs. These detailed plans shall also include the location of public convenience and advance warning signs to be used during the construction.
- B. Traffic control shall be coordinated for the minimum inconvenience and maximum safety of the public during the construction period. The Contractor shall bear full responsibility for maintaining traffic control during the construction period. Contractor shall maintain traffic circulation at all times during the project.
- C. The Contractor shall provide for safe movement of vehicular, bicycle and pedestrian traffic through and around construction operations. Traffic control requirements set forth herein and as shown on the Drawings are the minimum requirements imposed. The Contractor shall be solely responsible for providing all protective measures.
- D. "No Parking" signs shall be posted seventy-two (72) hours prior to start of work.
- E. The Contractor shall clean up the site each day after completing work and remove all traffic hazards. Daily traffic control measures shall continue until cleanup activities have been satisfactorily completed and all of the Contractor's equipment has been removed from the traveled way area.
- F. All traffic control items required by the City Engineer to maintain traffic shall be furnished and installed by the Contractor.

1.3 TRAFFIC CONTROL SUPERVISOR

- A. The Traffic Control System shall be placed, maintained, and removed under the direct supervision of a person who is certified by either the Institute of Transportation Studies (ITS), the American Traffic Safety Services Association (ATSSA), the International Municipal Signal Association, the State of California Department of Transportation (Caltrans) or other agency as approved by the City Engineer as having successfully completed training in the design and operation of work zone traffic control.
- B. The Contractor shall designate in writing the person who shall have the responsibility for supervising the activities associated with the Traffic Control System. This designation, along with proof of certification, shall be provided to the City Engineer for

approval, two (2) working days in advance of any planned activity that requires traffic control. The person designated shall have the authority to stop the work if necessary.

- C. Failure of the designated person to be present at the job site when any part of the Traffic Control System is in place shall be considered as failure on the part of the Contractor to perform a provision of the contract, and as such, the City Engineer may, in accordance with Section 8-1.06 "Suspensions" of the Caltrans Standard Specifications suspend all work until such time satisfactory arrangements have been made to have a certified person on the job site at all times when the Traffic Control System is in place. No additional compensation or additional working days will be allowed by reason of such suspension. The days on which the suspension is in effect shall be considered working days if such days are considered working days within the meaning of the definition set forth in Section 1-1.07 "Definitions" of the Caltrans Standard Specifications.

PART 2 - MATERIALS

2.1 CONSTRUCTION SIGNS

- A. Construction signs shall be furnished, installed, maintained, and removed when no longer required in conformance with the provisions in Section 12, "Temporary Traffic Control," of the Caltrans Standard Specifications, Manual on Uniform Traffic Control Devices and these Technical Specifications.
- B. All signs used during hours of darkness shall be reflectorized or illuminated.

2.2 FLASHING ARROW SIGNS

- A. Flashing arrow signs are to conform to the requirements of Section 12-3.30, "Flashing Arrow Signs" of the Caltrans Standard Specifications. Flashing arrow signs shall be Type II.

2.3 CONES OR DELINEATORS

- A. Traffic Control devices shall conform to the standards of the CA Manual on Uniform Traffic Control Devices.

PART 3 - EXECUTION

3.1 MAINTAINING TAFFIC

- A. The Contractor shall notify local authorities of the Contractor's intent to begin work at least 5 days before work is begun. The Contractor shall cooperate with local authorities relative to handling traffic through the area and shall make arrangements relative to keeping the working area clear of parked vehicles.
- B. Whenever vehicles or equipment are parked on the shoulder within 6 feet of a traffic lane, the shoulder area shall be closed with fluorescent traffic cones or portable delineators placed on a taper in advance of the parked vehicles or equipment and along the edge of the pavement at 25 foot intervals to a point not less than 25 foot past the last vehicle or piece of equipment. A minimum of 9 cones or portable delineators shall be used for the taper. A C23 (Road Work Ahead) or C24 (Shoulder Work Ahead) sign shall be mounted on a portable sign stand with flags. The sign shall be placed where designated by the City Engineer.

- C. No existing pavement shall be removed until all necessary traffic control devices have been installed to route traffic onto other paved portions of the roadway and such removal has been approved by the City Engineer.
- D. If any component in the traffic control system is displaced, or ceases to operate or function as specified, from any cause, during the progress of the work, the Contractor shall immediately repair said component to its original condition or replace said component and shall restore the component to its original location.

3.2 CONTRACTOR'S OPERATIONS

- A. When leaving a work area and entering a roadway carrying public traffic, the Contractor's equipment, whether empty or loaded, shall in all cases yield to public traffic. The Contractor's trucks or other mobile equipment which leave a traveled lane, that is open to public traffic, to enter the construction area, shall slow down gradually in advance of the location of the turnoff to give following public traffic an opportunity to slow down.
- B. The Contractor shall not use any private driveways or property to turn around or for temporary stockpile of material or staging areas unless written permission is obtained from the property owner by the Contractor. Copies of such permission shall be provided to the City Engineer prior to the use of the private property.
- C. If the Contractor does not furnish and maintain all signs or traffic control devices in accordance with these Specifications, the City shall temporarily suspend the work in accordance with the Caltrans Standard Specifications until deficiencies are corrected or shall perform the required work and bill the Contractor at double the rate of all City expenses.
- D. The full width of the traveled way shall be open for use by public traffic when construction operations are not actively in progress.

3.3 REOPENING

- A. A closed lane cannot be reopened to public traffic until temporary or permanent pavement delineation is in place.

3.4 PEDESTRIAN ACCESS

- A. Sidewalks will remain open to pedestrians whenever possible and if they need to be closed all pedestrians will be detoured to the opposite side of the street. Sidewalk related work will only be allowed to occur on one side of the street at a time. The Contractor will need to establish an acceptable travel route for pedestrians.

PART 4 - PAYMENT

4.1 MEASUREMENT AND PAYMENT

- A. **Traffic Control Plan** shall be measured by **lump sum** and paid for in accordance with Article 8 of the General Conditions and Section 01015 – SUMMARY OF BID ITEMS.

++ END OF SECTION ++

SECTION 02220 – DEMOLITION

PART 1 - GENERAL

1.1 SCOPE OF WORK

- A. Provide all materials, equipment, transportation, and incidentals required to complete all demolition and removal work as herein specified. Demolition work includes but is not limited to the areas as indicated in the Specification and other Contract Documents, and additional work as noted in this Section of the Specifications and other sections of the Specifications.

- B. Due care shall be exercised to avoid injury to existing improvements, adjacent property, and roadside trees, shrubs, and other plants that are not shown on the plans to be removed. Trees, shrubs, plants, power poles, pole lines, fences, traffic signs, markers, monuments, adjacent property, structures above and below ground that are not designated to be removed shall be protected from injury or damage. The Contractor, if ordered by the City Engineer, shall provide and install suitable safeguards, approved by the City Engineer, to protect such objects from injury or damage. If such objects are injured, damaged, or removed by reason of the Contractor's operations, they shall be immediately replaced or restored at the Contractor's expense

1.2 RECOVERABLE MATERIALS

- A. The Contractor must dispose of all recoverable materials in a proper and legal manner. The Contractor must include in the bid all costs for disposal.

PART 2 - MATERIALS

NOT USED

PART 3 - EXECUTION

3.1 SOLID WASTE MANAGEMENT

- A. Implement a recycling/reuse program that includes separate collection of waste materials of the following types as appropriate to the project waste and the available recycling and reuse programs in the project area:
 - 1. Land clearing debris.
 - 2. Asphalt.
 - 3. Concrete.
 - 4. Metal.
 - 5. Wood, nails, and staples.
 - 6. Debris.
 - 7. Glass.

8. Paper, cardboard and paper packaging materials.

9. Plastic.

PART 4 - PAYMENT

4.1 MEASUREMENT AND PAYMENT

A. Full compensation for conforming to the requirements of this section shall be considered as included in the prices paid for the various contract items of work involved and no additional compensation will be allowed.

++ END OF SECTION ++

SECTION 02225 – CLEARING AND GRUBBING

PART 1 - GENERAL

1.1 SPECIFICATIONS

- A. Clearing and grubbing shall conform to Section 17-2, "Clearing and Grubbing", of the Caltrans Standard Specifications.

1.2 SCOPE OF WORK

- A. Clearing and grubbing consists of removal and disposal of all objectionable material from the project site, including existing weeds, brush, shrubs, concrete, masonry, other unsuitable material, and obstructions interfering with the new construction. The limits of clearing and grubbing shall be of sufficient area and depth to complete the work as shown on the plans.
- B. Due care shall be exercised to avoid injury and damage to existing improvements, adjacent property, roadside trees, shrubs, and other plants that are not shown on the plans to be removed.
- C. Clearing and grubbing must be performed in advance of any other grading or construction operations. The area to be cleared and grubbed must be within the construction area.
- D. Prior to applying microsurfacing, the contractor shall completely remove all vegetation and weeds, including the root system, within the pavement surface including around manhole covers, valve covers, and at the lip of gutter. Notify the Engineer after vegetation removal work has completed for approval, at least 24 hours before commencing slurry seal operation.

1.3 LANDSCAPING

- A. Shrubs and hedges shall be designated for removal in the project plans or as directed by the Engineer. Shrubs and hedges overhanging the curb that interfere with construction operations shall be cut back as directed by the Engineer. Existing landscaping and trees which are to remain in place must be protected from injury or damage. Existing trees must be protected with a temporary fence around the drip line.
- B. Unless otherwise specified, the Contractor shall protect trees at the Contractor's expense. Trees, bushes, and shrubs shall be removed in such a manner consistent with the health and safety of the tree climbing crew, the general public, and as to not injure standing trees, plants, and improvements which are to be preserved. Felled trees, shrubs, and bushes may be cut into sections and removed from the site. All branches, leaves, and vegetative debris may be reduced to chips. All resulting stumps are to be routed to a minimum of twenty-four (24) inches below the soil level.
- C. Unless otherwise specified, all materials as shown on the drawings to be removed, or as field marked and as directed by the Engineer to be removed shall be disposed of outside the project limits. The Contractor work area shall be left with a neat and finished appearance.

- D. The Contractor shall not store or permit debris to accumulate on site. If Contractor fails to remove excess debris promptly, the City reserves the right to cause removal at the Contractor's expense.
- E. Residue from cutting operations shall not be permitted to flow into storm drains or across lanes occupied by traffic and shall be removed from the pavement surface, concurrent with the cutting operation.
- F. Clearing and grubbing must be conducted to ensure minimum interference with roads, street, walks, or other occupied areas.

1.4 ROOT CUTTING

- A. The contractor shall notify the City Inspector of any root (**over 2 inches in diameter**) that needs to be cut. The City Inspector will inspect and document the root within 24 hours of the notification. The root cannot be damaged until approval from the City Inspector.

PART 2 - MATERIALS

NOT USED

PART 3 - EXECUTION

NOT USED

PART 4 - PAYMENT

4.1 MEASUREMENT AND PAYMENT

- A. Full compensation for conforming to the requirements of this section shall be considered as included in the prices paid for the various contract items of work involved and no additional compensation will be allowed.

++ END OF SECTION ++

SECTION 02230 – TREE REMOVAL

PART 1 - GENERAL

1.1 SPECIFICATIONS

- A. Removal of trees and tree stumps shall conform to the provisions in Section 17-2 “Clearing and Grubbing” of the Standard Specifications and these Contract Documents.

1.2 SCOPE OF WORK

- A. Provide all labor, equipment, materials, and supervision required to remove designated trees, including cutting, dismantling, stump removal, disposal of debris, and site restoration.
- B. Tree removal locations are identified herein for information only. Final determination of trees to be removed shall be verified in the field after removal of existing concrete and confirmation of conflicts with proposed improvements.

C. Locations

1. 2846 Spanish Bay Drive
2. 1605 Montclair Place
3. 1880 Connor Way
4. 426 Iron Club Drive
5. 615 Kenwood Drive
6. 1917 Water Street
7. 2160 Gold Poppy Court
8. 338 Chelmsford Drive
9. 339 Chelmsford Drive
10. 345 Chelmsford Drive
11. 523 Taylor Drive
12. 3070 Emerson Lane
13. 1792 Moreau Way
14. 2260 Balfour Way
15. 1400 Sweetbriar Court

PART 2 - MATERIALS

NOT USED

PART 3 - EXECUTION

3.1 FIELD CONDITIONS

- A. The Contractor shall verify existing field conditions prior to performing any tree removal activities.
- B. No tree removal shall occur until existing concrete has been removed and any conflicts with the proposed work have been verified and approved by the Engineer.

3.2 TREE REMOVAL

- A. Tree stumps shall be completely removed to a minimum depth of two (2) feet below adjacent grade. Resulting voids shall be backfilled with approved native or imported material.

3.3 DISPOSAL

- A. All wood, branches, chips, and debris generated by tree removal operations shall be removed from the site unless otherwise specified.
- B. Materials shall be disposed of at facilities approved by the governing authority.

3.4 RESTORATION

- A. The Contractor shall repair or replace any pavement, irrigation systems, or landscaping damaged as a result of tree removal operations.
- B. Stump removal areas shall be backfilled with approved material and compacted to surrounding grade.
- C. Upon completion of work, the site shall be left in a clean, safe condition free of hazards.

PART 4 - PAYMENT

4.1 MEASUREMENT AND PAYMENT

- A. **Remove Tree** shall be measured by **Each** and paid for in accordance with Article 8 of the General Conditions and Section 01015 – SUMMARY OF BID ITEMS.

++ END OF SECTION ++

SECTION 02400 – LINES AND GRADE

PART 1 - GENERAL

1.1 SPECIFICATIONS

- A. Lines and Grades shall conform to the provisions, Section 7.17 “Lines and Grades” of the General Conditions, and these Specifications.

1.2 SCOPE OF WORK

- A. Contractor shall be responsible for all construction staking or surveying required for the project.
- B. Contractor shall maintain completed slopes and repair any slope damage caused by erosion.

PART 2 - MATERIALS

NOT USED

PART 3 - EXECUTION

3.1 GRADE

- A. Contractor shall conform to existing grades while conforming to The American with Disabilities Act and preventing ponding. If the grades do not comply with these requirements, the Contractor shall propose a grade that will be reviewed by the City Engineer.

PART 4 - PAYMENT

4.1 MEASUREMENT AND PAYMENT

- A. Full compensation for conforming to the requirements of this section shall be considered as included in the prices paid for the various contract items of work involved and no additional compensation will be allowed.

++ END OF SECTION ++

SECTION 02500 – AGGREGATE BASE

PART 1 - GENERAL

1.1 SPECIFICATIONS

- A. Aggregate base shall be Class 2 and shall conform to the provisions in Section 26, "Aggregate Bases", of the Standard Specifications and these Specifications.

1.2 SCOPE OF WORK

- A. This work shall consist of furnishing, placing and compacting Class 2 aggregate base as shown on the plans, as specified in the Standard Specifications and these technical specifications, and as directed by the Engineer.
- B. Contractor shall maintain completed slopes and repair any slope damage caused by erosion.

PART 2 - MATERIALS

2.1 CLASS 2 VIRGIN AGGREGATE BASE

- A. Aggregate shall conform to the grading and quality requirements as shown in Section 26, "Aggregate Bases", of the Caltrans Standard Specifications.
- B. The coarse aggregate (material retained on the No. 4 sieve) shall consist of material of which at least 25% by weight shall be crushed particles as determined by California Test 205.
- C. Aggregate base shall not consist of any recycled material or products such as "Sierra-Crete" by Dupont, or the like.
- D. **Recycled Aggregate Base material will only be allowed under sidewalk.**
- E. **No Recycled Aggregate Base shall be used under roadway or gutter.**

PART 3 - EXECUTION

3.1 GENERAL

- A. Prior to excavation for aggregate base section, Contractor shall contact Underground Service Alert for identification of underground facilities, including water, sewer, and storm drain lines.
- B. The Contractor shall ensure the sub-base or subgrade is compacted to 95% relative density before placing aggregate base.

3.2 PLACEMENT

- A. The aggregate base shall be placed and graded as necessary to conform to grade of proposed surfacing. The amount of aggregate base necessary will vary depending on the finished grades to achieve conforming slopes.

3.3 COMPACTION

- A. The relative density of each layer of compacted aggregate base rock material shall be not less than 95 percent. Testing shall be as determined by the ASTM D1557 test method.
- B. Compaction testing of the work shall be at the direction of the City Engineer. Initial compaction testing will be the responsibility of the City Engineer. However, the Contractor shall be responsible for all costs associated with the retesting of areas which fail to meet the specifications.
- C. The maximum compacted thickness of any one layer of aggregate base must not exceed 6 inches.

PART 4 - PAYMENT

4.1 MEASUREMENT AND PAYMENT

- A. **Class 2 Aggregate Base** shall be measured by **Ton** and paid for in accordance with Article 8 of the General Conditions and Section 01015 – SUMMARY OF BID ITEMS.

++ END OF SECTION ++

SECTION 03200 – STEEL REINFORCEMENT

PART 1 - GENERAL

1.1 SPECIFICATIONS

- A. Reinforcement shall conform to the applicable provisions in Section 52 “Reinforcement” of the Caltrans Standard Specifications and these Specifications.

1.2 SCOPE OF WORK

- A. The work associated with this Section includes providing all concrete reinforcement steel, welded wire fabric, couplers, and concrete inserts for use in reinforced concrete and masonry construction, including all the wires, clips, supports, chairs, spacers, and other accessories.

PART 2 - MATERIALS

2.1 REINFORCING BARS

- A. ASTM A615, Grade 60 for all non-welded bars. ASTM A706, Grade 60 for welded bars.

2.2 WELDED WIRE FABRIC REINFORCEMENT

- A. ASTM A1064.

2.3 SMOOTH STEEL DOWELS

- A. ASTM A36.
- B. Epoxy coated conforming to ASTM A775 or ASTM A934.

2.4 STEEL WIRE

- A. ASTM A82.

2.5 COLUMN SPIRALS

- A. Hot-rolled rods for spirals, ASTM A615.

2.6 MECHANICAL COUPLERS

- A. Reinforcement may be spliced with a mechanical connection. Provide a full mechanical connection which shall develop in tension or compression, as required, at least 125% of specified yield strength (f_y) of the bar in accordance with ACI 318 Section 12.14.3.2. The locations of the connections are subject to the approval of the Engineer.

2.7 THREADED SPLICING SYSTEMS

- A. Dowel Bar Splicer System shall comply with ICC Report #4028. The completed splice shall exceed 160% of the specified yield strength (f_y) of the bar.

2.8 ACCESSORIES FOR REINFORCEMENT

- A. Bolsters, chairs, spacers and other devices for spacing, supporting and fastening reinforcement in place.
- B. All bar supports shall meet the requirements of the CRSI Manual of Standard Practice including special requirements for supporting epoxy coated reinforcing bars.
- C. Concrete blocks (dobies), used to support and position reinforcement steel, shall have the same or higher compressive strength as specified for the concrete in which it is located, and be used for horizontal bars at grade only. Wire ties shall be embedded in concrete block bar supports.
- D. Epoxy coating for reinforcing and accessories, where specified or shown, shall conform to ASTM A775.

PART 3 - EXECUTION

3.1 STORAGE

- A. Reinforcing, embeds and accessories shall be kept clean and free from dirt or grease.
- B. Reinforcement steel shall at all times be protected from conditions conducive to corrosion until concrete is placed around it. Mild non-flaking surface rust is acceptable.
- C. Epoxy coated reinforcing bars shall be stored, transported, and placed in such a manner as to avoid chipping of the epoxy coating. Non-abrasive slings made of nylon and similar materials shall be used. Specially coated bar supports shall be used. All chips or cracks in the epoxy coating shall be repaired with a compatible epoxy repair material prior to placing concrete.

3.2 INSTALLATION

- A. Comply with the applicable recommendations of specified codes and standards, and CRSI, Manual of Standard Practice, for details and methods of reinforcement placement and supports.
- B. Clean reinforcement to remove loose rust and mill scale, oil, earth, ice, and other materials that reduce or destroy bond with concrete.
- C. Reinforcement steel shall be accurately positioned and shall be supported and wired together to prevent displacement, using annealed iron wire ties or suitable clips at intersections. All reinforcement steel shall be supported by concrete, plastic or metal supports, spacers or metal hangers that are strong and rigid enough to prevent any displacement of the reinforcement steel.
- D. Where concrete is to be placed on the ground, supporting concrete blocks (or dobies) shall be used, in sufficient numbers to support the bars without settlement, but in no case shall such support be continuous. All concrete blocks used to support reinforcement steel shall be tied to the steel with wire ties that are embedded in the blocks.

- E. For concrete over formwork, the Contractor shall furnish concrete, metal, plastic, or other acceptable bar chairs and spacers.
- F. Tie wires shall be bent away from the forms in order to provide the specified concrete coverage.
- G. Bars may be moved as necessary to avoid interference with other reinforcement steel, conduits, or embedded items. If bars are moved more than one bar diameter, or enough to exceed the above tolerances, the resulting arrangement of bars shall be subject to the approval of the Engineer.
- H. Welded wire fabric reinforcement placed over horizontal forms shall be supported on slab bolsters. Slab bolsters shall be spaced not more than 30 inches on centers, shall extend continuously across the entire width of the reinforcement mat, and shall support the reinforcement mat in the plane indicated.
- I. Accessories supporting reinforcing bars shall be spaced such that there is no deflection of the accessory from the weight of the supported bars. When used to space the reinforcing bars from wall forms, the forms and bars shall be located so that there is no deflection of the accessory when the forms are tightened into position.
- J. Tack welding of reinforcing bar is prohibited.

3.3 BENDING

- A. Reinforcement shall not be straightened or rebent in a manner that will injure the material. Bars with kinks or bends not shown shall not be used. All bars shall be bent cold, unless otherwise permitted by the Engineer. Bars partially embedded in concrete may be field-bent one time at an angle up to 30 degrees, and bent back to its original position. Rebending more than once will render the bar unacceptable.

3.4 INSPECTION

- A. Engineer shall be provided at least 24 hours advance notice to schedule inspections.
- B. Do not place concrete until the reinforcing steel is inspected and permission for placing concrete is granted by the Engineer. All concrete placed in violation of this provision will be rejected.

PART 4 - PAYMENT

4.1 MEASUREMENT AND PAYMENT

- A. Full compensation for conforming to the requirements of this section shall be considered as included in the prices paid for the various contract items of work involved and no additional compensation will be allowed.

++ END OF SECTION ++

SECTION 03300 – CAST-IN-PLACE CONCRETE

PART 1 - GENERAL

1.1 SPECIFICATIONS

- A. Structural concrete shall conform to the applicable provisions in Section 51 “Concrete Structures” of the Caltrans Standard Specifications and these Specifications.
- B. Minor concrete (curb ramp, sidewalk, driveway, curb and gutter) shall conform to the applicable provisions in Section 73 “Concrete Curbs and Sidewalk” and Section 90 “Concrete” of the Caltrans Standard Specifications and these Specifications.
- C. Attention is directed to Section 15, “Existing Facilities” of the Caltrans Standard Specifications for existing facilities requiring adjustment to grade, removal, and/or resetting.
- D. Minor Concrete shall conform to City Standard Plan ST-7, ST-8, ST-17, ST-18, ST-21, ST-23 and as detailed on the plans. Curb ramp shall be adjusted by the City Engineer to fit field conditions. Sidewalks, curbs, curbs and gutters shall conform to City Standard Plan ST-23 and as detailed on the plans.

1.2 SCOPE OF WORK

- A. The work to be done consists of sawcutting, demolition and removal of existing Portland Cement Concrete (PCC or “concrete”) hardscape, excavation and removal of existing ground materials, grading and compaction of subgrade and imported aggregate base rock, concrete construction for utility adjustments, and related items of work of the form and dimensions as shown on the plans, as specified in the Standard Specifications and these technical specifications, and as directed by the Engineer.

1.3 SUBMITTALS

- A. Submit concrete mix design for each concrete type per ACI 301:
 - 1. Mix proportions
 - 2. Concrete materials
 - 3. Admixtures
 - 4. Water test results
- B. Curing methods and product data per ACI 301.
- C. Repair procedures for repair per ACI 224.1 and ACI 301.
- D. Special procedures for hot weather concreting.
- E. Special procedures for cold weather concreting.
- F. Special procedures for mass concrete.

PART 2 - MATERIALS

2.1 MINOR CONCRETE

- A. Materials for concrete work shall conform to Section 90 "Concrete" of the Caltrans Standard Specifications, and as modified by the City's Standard Specifications to include Fibrous Concrete Reinforcement to all concrete mixes.

2.2 ASPHALT OVERCUT

- A. Asphalt concrete (AC), used in connection with curb ramp or gutter reconstruction, shall be Type A and shall be produced at a central mixing plant. Grade of asphalt binder for AC Type A shall be PG 64-10. The aggregate for AC Type A must comply with the 1/2 inch grading.
- B. Aggregate Base for the overcut shall conform to Section 02500 Aggregate Base.

2.3 STRUCTURAL CONCRETE

- A. Materials for concrete work shall conform to Section 51 "Concrete Structures" of the Caltrans Standard Specifications, and as modified by the City's Standard Specifications.

PART 3 - EXECUTION

3.1 DEMOLITION

- A. Reconstructed handicap ramps, sidewalks, and/or curbs shall be poured within 48 hours of demolition.
- B. Asphalt concrete pavement removed in connection with handicap ramp and/or curb construction shall be completely replaced within 48 hours of pouring new concrete.

3.2 PREPARATION

- A. Construction shall not be commenced until the applicable submittals have been approved by the Engineer.

3.3 STRUCTURAL CONCRETE INSTALLATION

- A. Placement of fresh concrete per ACI 301.
- B. Depositing fresh concrete per ACI 301 with the following requirements:
 - 1. For hot weather conditions, maximum time from batching to discharge shall not exceed 45 minutes.
 - 2. For normal weather conditions, maximum time from batching to discharge shall not exceed 60 minutes.
 - 3. Time between lift placement shall not exceed 30 minutes for hot weather placement; 60 minutes otherwise.
- C. Consolidate fresh concrete per ACI 301.

- D. Construction joints: Contractor shall not move construction joints from locations shown on Construction Drawings without approval by Engineer.
- E. Protection of concrete shall conform to ACI 301.

3.4 MINOR CONCRETE INSTALLATION

- A. All new PCC improvements shall be doweled to existing PCC improvements as directed by the City Engineer using twelve inch (12") long No. 3 rebar. Generally, dowels shall be placed three feet (3') on center longitudinally when adjacent to existing PCC improvements with a minimum of two (2) equally spaced dowels. Two (2) equally spaced dowels shall be placed at each conform to existing PCC sidewalk or curb ramp and at each full width expansion joint. Dowels shall be drilled for tight fit and epoxied in place.
- B. Any sidewalk replacement with a tree remaining in place, must have a rebar mat placed that meet the requirements of ASTM A184.
- C. Utilities, Landscaping, yard drain pipes, and sprinkler heads and lines located near the existing back of sidewalk or sidewalk ramp shall be protected from damage. Sewer cleanouts located near the existing back of sidewalk or curb ramp shall also be protected from damage and remain free of debris. Any damage shall be repaired at the Contractor's expense to the satisfaction of the City Engineer.
- D. A minimum of 4 inches of class 2 aggregate base shall be placed under curb ramps, driveways, curbs, curb and gutters, and/or sidewalks and shall conform to the requirements specified elsewhere in these Technical Specifications.

3.5 REBAR MAT

- A. A rebar mat shall be installed in all sidewalk near a tree.
- B. The rebar mat shall be eight feet by the width of the sidewalk. The rebar shall be 3/8" and 16" on center.

3.6 ASPHALT OVERCUT

- A. The overcut section shall be two foot wide by twelve inches deep, at a minimum.
- B. The Asphalt Concrete shall match the existing asphalt concrete section (minimum of 4 inches). The remaining section shall be Aggregate Base.
- C. Prior to the placement of the AC, the Contractor shall apply a tack coat to the horizontal and vertical faces of the existing asphalt pavement.
- D. AC shall be placed in lifts with thickness no less than 1.5 inches and no greater than 3 inches. The AC shall be placed and compacted to ninety five percent (95%) density and shall meet the elevation of the existing pavement contour and lip of gutter at ramp.
- E. Areas inaccessible to rollers shall be compacted by use of a power compactor of the high impact, vibrate plate type, capable of attaining the same compaction as the rolled areas. Relative compaction will be determined by California Test 375.

- F. AC shall be placed only when the atmospheric temperature is a minimum of 50 degrees Fahrenheit and rising.

3.7 REPAIR

- A. Repair shall be per ACI 301 with the following requirements:
 - 1. Patching mortar shall be Sikatop 123 Plus or approved equal.
 - 2. Use Sikadur 32 HiMod bonding agent or approved equal.
 - 3. Honeycombs and defects deeper than 38 mm (1.5 inches) shall require approval by Engineer prior to commencing repair work.
 - 4. Cracks wider than 1 mm (0.04 inches) shall be repaired.

3.8 CURB DRAIN

- A. Contractor shall be made aware the work associated with repairing, extending, or replacing through-curb drains is included in the **Reconstruct Sidewalk, Reconstruct Driveway Approach, Reconstruct Curb and Gutter** and **Reconstruct ADA Ramp** bid items and no other compensation will be given.
- B. Any previously damaged sidewalk curb drain shall be repaired before placement of fresh concrete. The curb drain shall be extended or rerouted to the curb cut.
- C. Any damage that is caused by the Contractor shall be repaired at the Contractors expense.

PART 4 - PAYMENT

4.1 MEASUREMENT AND PAYMENT

- A. **Reconstruct Sidewalk** and **Reconstruct Driveway Approach** shall be measured by **square feet** and paid for in accordance with Article 8 of the General Conditions and Section 01015 – SUMMARY OF BID ITEMS.
- B. **Reconstruct Curb and Gutter** shall be measured by **linear feet** and paid for in accordance with Article 8 of the General Conditions and Section 01015 – SUMMARY OF BID ITEMS.
- C. **Adjust Utility to Grade** shall be measured by **each** and paid for in accordance with Article 8 of the General Conditions and Section 01015 – SUMMARY OF BID ITEMS
- D. **Reconstruct ADA Ramp** shall be measured by **each** and paid for in accordance with Article 8 of the General Conditions and Section 01015 – SUMMARY OF BID ITEMS.

++ END OF SECTION ++

SECTION 03315 – TRUNCATED DOMES

PART 1 - GENERAL

1.1 SPECIFICATIONS

- A. Truncated Domes shall conform to City of Brentwood Standard Plan ST-21c and these Specifications.
- B. City of Brentwood Standard Plan ST-21a, ST-21b, ST-21c, ST-21d, ST-21e

1.2 SCOPE OF WORK

- A. This work shall consist of furnishing and placing truncated domes on ADA ramps as shown on the plans, as specified in the Standard Specifications and these technical specifications, and as directed by the Engineer.
- B. Prefabricated detectable warning surface shall be in conformance with the requirements established by the Department of General Services, Division of State Architect and be attached in conformance with the manufacturer's recommendations.
- C. These truncated domes surfaces shall match the slopes of the surrounding pathway.
- D. All replaced curb ramps shall have detectable warning surface.

1.3 WARRANTY

- A. The manufacturer shall provide a written 5-year warranty for prefabricated detectable warning surfaces, guaranteeing replacement when there is defect in the dome shape, color fastness, sound-on-cane acoustic quality, resilience, or attachment. The warranty period shall begin upon acceptance of the contract.

PART 2 - MATERIALS

2.1 TRUNCATED DOMES

- A. Truncated domes shall be manufactured from Armor-Tile, EqualTile, or approved equivalent.
- B. The color of the detectable warning surface shall be **Yellow**.

PART 3 - EXECUTION

NOT USED

PART 4 - PAYMENT

4.1 MEASUREMENT AND PAYMENT

- A. Full compensation for conforming to the requirements of this section shall be considered as included in the prices paid for the various contract items of work involved and no additional compensation will be allowed.

++ END OF SECTION ++

SECTION 03400 – ASPHALT CONCRETE

PART 1 - GENERAL

1.1 SPECIFICATIONS

- A. Asphalt Concrete shall be Type A conforming to the provisions in Section 39 "Asphalt Concrete" with a maximum 15% Reclaimed Asphalt Pavement ("RAP") of the Caltrans Standard Specifications and these Technical Specifications.
- B. Bituminous binder shall conform to the provisions in Section 92 "Asphalt Binders" of the Caltrans Standard Specifications and these Technical Specifications.
- C. City of Brentwood Standard Plan ST-37

1.2 SCOPE OF WORK

- A. This work shall consist of the removal and replacement of existing pavement materials to the depths and dimensions marked in the field and/or described in the plans, and in accordance with the Caltrans Standard Specifications, these Technical Specifications, and/or as directed by the City Engineer.

PART 2 - MATERIALS

2.1 ASPHALT BINDER

- A. Bituminous binder shall be steam refined paving asphalt PG 64-10 conforming to the provisions in Section 92 "Asphalt Binders" of the Caltrans Standard Specifications and these Technical Specifications.

2.2 AGGREGATES

- A. Asphalt concrete shall be produced at a central mixing plant. Asphalt concrete shall be Type A 1/2" Max., Medium and shall conform to the provisions in Section 39-2.02B(4) "Aggregates" of the Caltrans Standard Specifications and these Technical Specifications.
- B. Aggregate Base for the overcut shall conform to Section 02500 Aggregate Base.

2.3 MIX DESIGN TOLERANCES

<u>Test</u>	<u>Individual Test Results</u>	<u>Test Method No. Calif.</u>
Loss in L.A. Rattler (after 500 rev.)	45% Max	211
Kc and Kf	1.8 Max	303
Sand Equivalent	45 Min	217
Stabilometer Value 3/4"	35 Min	304
1/2"	35 Min	304
3/8"	30 Min	304
Moisture Vapor Susceptibility	25 Min	307
Swell	0.030" Max	305

Lab Compacted Density	304
Maximum Specific Gravity	ASTM D-2041
Air Voids Content %	3 Min - 4.5 Max

2.4 CERTIFICATES OF COMPLIANCE

- A. Certificates of Compliance, in accordance with Section 6-2.03C, "Certificates of Compliance" of the Caltrans Standard Specifications, shall be required from the supplier of the asphalt concrete and delivered to the City Engineer not less than ten (10) working days prior to any scheduled asphalt concrete paving.

2.5 TACK COAT

- A. Tack coat shall be asphalt emulsion grade SS-1 furnished and applied in conformance with the provisions in the City Standard Plans and Specifications for Section 39-2.01C(3)(f) "Tack Coat", and Section 94 "Asphaltic Emulsions" of the Caltrans Standard Specifications, and these Technical Specifications, and shall be applied to all surfaces of concrete gutter and to existing roadway surfacing that will come into contact with asphalt concrete.
- B. The area to which tack coat has been applied shall be closed to public traffic. Care shall be taken to avoid tracking binder material onto existing pavement surfaces beyond the limits of construction. The surface shall be free of water, foreign material, or dust, when tack coat is applied.

2.6 GEOGRID

- A. Geogrid shall be Tensar TX 130S or approved equal for subgrade and pavement fabric shall be Tensar GlasPave 50 or approved equal for asphalt concrete.

PART 3 - EXECUTION

3.1 EQUIPMENT

- A. The cold planing machine shall be operated so as not to produce fumes or smoke. The cold planing machine shall be capable of planing the pavement without requiring the use of a heating device to soften the pavement during or prior to the planing operation.

3.2 GRINDING OPERATION

- A. Prior to beginning any grind and overlay work, the Contractor shall arrange for and conduct a field review of each grind and overlay with the City Engineer. The City Engineer and Contractor shall record the agreed upon dimensions for each repair at each location. Size of the grind and overlay shall not vary from this agreement unless specified in writing by the City Engineer. Additional compensation shall not be allowed for grind and overlays in excess of the agreed upon size.
- B. Planing asphalt concrete shall be performed by the cold planing method. Planing of the asphalt concrete pavement shall not be done by the heater planing method. The depth, width and shape of the cut shall be as marked in the field and directed by the City Engineer. The final cut shall result in a uniform surface. The outside lines of the

planed area shall be neat and uniform. Planing asphalt concrete pavement shall be performed without damage to the surfacing to remain in place.

- C. Any sections of asphalt that become loose after grinding shall be removed and disposed of by the Contractor at the Contractor's expense. If grinding operations begins to pulverize the asphalt concrete to remain the Contractor shall notify the City Engineer immediately. In locations where the grinding operation begins to pulverize the remaining asphalt concrete, the Contractor shall use a smaller grinder to prevent asphalt concrete damage. Depending on the depth of the milling or grinding operations, subgrade may be encountered.
- D. The material planed from the roadway surface, including material deposited in existing gutters, driveways, around structures, or on the adjacent traveled way, shall be removed and hauled away in accordance with the Contract Documents. The City reserves the first right to the pavement grindings. Removal operations of cold-planed material shall be concurrent with planing operations and follow within 50 feet of the planer, unless otherwise directed by the City Engineer.
- E. The Contractor shall furnish and operate a self-loading motor sweeper with spray nozzles for final clean-up work and shall keep the milled area cleaned and maintained at all times until the street has been resurfaced.
- F. The Contractor is notified that existing pavement fabric may be encountered in the areas to be ground. If pavement fabric substantially hinders the progress of grinding as determined by the City Engineer, the Contractor will be given additional contract days to accomplish grinding operations. No additional compensation beyond the unit price bid for Grind and Overlay will be made to the Contractor based on the presence of fabric in the sections to be ground or the presence of existing asphalt above the lip of gutter.

3.3 SUBGRADE

- A. Upon removing all existing material to the required depth, all loose material shall be removed to a solid surface (95% Relative Compaction) or the Contractor shall compact the upper 12 inches of the subgrade (or aggregate base) to not less than 95% relative compaction. Any import base material needed to meet the requirement for this work shall be provided by the Contractor to the site and compacted to 95% relative compaction by the Contractor at no additional expense to the City.

3.4 TEMPORARY STRIPING

- A. For areas with full width grind, after the grinding is complete and prior to opening the street to traffic the Contractor shall place temporary striping and legends with paint. Tabs will not be accepted for full width grind locations. For areas with full width grind, the work shall also include end conforms a minimum taper length of 30 feet.

3.5 GEOGRID

- A. Geogrid and pavement fabric shall be installed under all proposed aggregate base and repaved areas.
- B. Geogrid shall be Tensar TX 130S or approved equal for aggregate base for pavement failure repair areas, and pavement fabric shall be Tensar GlasPave 50 or approved equal for asphalt concrete for all "Asphalt Concrete Pavement" areas.

- C. Geogrid and pavement fabric shall be installed in accordance with the Contract Documents and per the manufacturer's instructions.

3.6 SPREADING AND COMPACTING

- A. Asphalt concrete shall be placed only when the atmospheric temperature is a minimum of 50°F and rising.
- B. Prior to the placement of the asphalt concrete, the Contractor shall apply a tack coat to the horizontal and vertical faces of the existing asphalt pavement.
- C. The Contractor shall not excavate any more area of existing asphalt pavement than can be completed by the end of the workday. All excavations shall be backfilled with the final asphalt section by the end of each working day.
- D. The Contractor shall not perform paving operations when the weather is rainy or foggy. Determination of inclement weather shall be made by the City Engineer. If the day's operations are canceled because of fog or rain, a non-working day will be allowed only as specified under section 1-1.07, "Definitions," of Caltrans Standard Specifications.
- E. Contractor shall receive the approval of the City Engineer before placing any asphalt concrete on the roadway. Asphalt concrete shall not be placed on any surface which contains ponded water or excessive moisture nor in any unapproved location, as determined by the City Engineer.
- F. If paving operations are in progress and rain or fog forces a shutdown, loaded trucks shall return to the plant and no compensation will be allowed therefor. The Contractor shall furnish and use canvas tarpaulins to cover all loads of asphalt concrete from the time that the mixture is loaded until it is discharged from the delivery vehicle, unless otherwise directed in writing by the City Engineer.
- G. No traffic shall be allowed on the asphalt emulsion with the exception of vehicles unloading asphalt concrete. All vehicles involved with the Contractor's operations shall turn around within the road right-of-way. Driveways and other private property shall not be used without prior written consent of the involved property owner, a dated copy of which shall be delivered to the City Engineer prior to the use thereof.
- H. The area to which tack coat has been applied shall be closed to public traffic. Care shall be taken to avoid tracking tack coat material onto existing pavement surfaces beyond the limits of construction.
- I. Longitudinal and transverse conforms between existing pavement and newly constructed pavement shall be made by cutting the existing pavement to a neat, smooth line at the conform line and constructing a vertical-face butt joint.
- J. A drop-off of more than 0.15 foot will not be allowed at any time adjacent to traveled lanes of asphalt concrete surfacing.
- K. Asphalt concrete shall be placed in lifts with thickness no less than 1.5 inches and no greater than 3 inches. The asphalt concrete shall be placed and compacted to 96% density and shall meet the elevation of the existing pavement contour. Areas inaccessible to rollers shall be compacted by use of a power compactor of the high impact, vibratory plate type, capable of attaining the same compaction as the rolled

areas. Relative compaction will be determined by California Test 375. No single test shall be less than 95%. Areas not passing the specified compaction will be reworked until proper compaction is achieved.

3.7 THICKNESS AT LIP OF GUTTER

- A. Asphalt concrete placed adjacent to any fall-away gutter shall be placed flush with the lip of gutter. Asphalt concrete placed adjacent to any gutter designed to carry water shall be 0 inches to 0.25 inch above the gutter lip after final compaction, but in no case shall it be more than 0.25 inch.
- B. Any areas greater than 0.25 inch shall be repaired by wedge grinding a minimum depth of 1 inch and repaving as directed by the City Engineer.
- C. Asphalt concrete placed adjacent to any gutter designed to shed water shall be flush with the gutter lip after final compaction.

3.8 ASPHALT CONCRETE SIDEWALK

- A. Asphalt Concrete placed as sidewalk shall be according to City of Brentwood Standard Detail L-7 and shall be 1/2" Type A (1/2" Max., Medium).

PART 4 - PAYMENT

4.1 MEASUREMENT AND PAYMENT

- A. Full compensation for conforming to the requirements of this section shall be considered as included in the prices paid for the various contract items of work involved and no additional compensation will be allowed.

++ END OF SECTION ++

SECTION 04000 – STRIPING AND MARKINGS

PART 1 - GENERAL

1.1 SPECIFICATIONS

- A. Traffic stripes and pavement legends including crosswalks shall be placed as shown on the plans, as specified in Section 84, "Markings," and Section 81-3, "Pavement Markers," of the Caltrans Standard Specifications as modified herein, and as directed by the City Engineer.
- B. City of Brentwood Standard Plan ST-15a, ST-15b, ST-15c, ST-15d, ST-20, ST-28, ST-36, ST-38

1.2 SCOPE OF WORK

- A. Configuration of traffic stripes, pavement markings and crosswalks shall conform to the detail and methods as set forth in the latest issue of the State of California, Department of Transportation Traffic Manual unless specifically modified on the plans.
- B. Existing traffic stripes, pavement markings and pavement markers that are outside the areas of the asphalt concrete pavement overlay and/or slurry seal that are to remain in place shall be protected from wheel marks and other damage by the Contractor.
- C. Damaged traffic stripes, pavement markings and pavement markers shall be cleaned or replaced as approved by the City Engineer. The restoration of such objects will be at the Contractor's expense and in conformance with City Standards.
- D. At the option of the Contractor, a hot melt bitumen adhesive may be used to cement the markers to the pavement, instead of the Rapid Set Type or Standard Set Type adhesive specified in Section 81-3.02E and 81-3.03C "Epoxy Adhesive", of the Caltrans Standard Specifications. The bitumen adhesive material, if used, shall conform to the following the requirements below.

PART 2 - MATERIALS

2.1 STRIPING

- A. Permanent striping and pavement markings shall be thermoplastic.

2.2 BITUMEN ADHESIVE

Flash Point, COC, °F	ASTM D92	550 Min.
Softening Point, °F	ASTM D36	200 Min.
Brookfield Viscosity, 400°F	ASTM D2196	7,500 CP, Max.
Penetration, 100g, 5 sec.	ASTM D5	10-20 dmm 70°F
Filler content, % by weight (insoluble in 1,1,1, Trichloromethane)	ASTM D2371	50-75

2.3 FILLER MATERIAL

A. Filler material shall be calcium carbonate and shall conform to the following fineness:

Sieve Size	Percent Passing
No. 100	100
No. 200	95
Bo. 325	75

PART 3 - EXECUTION

3.1 STRIPING

- A. The Contractor shall coordinate with the City Engineer prior to the restriping of any street.
- B. Contractor shall place control points spaced at 200 feet on tangents and 50 feet' on curves for City Engineer to review and approve. No additional "cat tracks" shall be placed until control points are approved by the City Engineer.
- C. The Contractor shall make all necessary conform striping as required. Stripes shall be sharp and clear. The Contractor shall remove by sandblasting or grinding any and all striping that conflicts with new pavement markers or new striping. All sand and paint residue from sandblasting operations shall be removed from the pavement during the same work-shift the sand blasting occurred.
- D. Thermoplastic material for traffic stripes shall be applied at a minimum thickness of 0.07 inch.
- E. The Contractor shall place and remove any temporary striping required for routing traffic through the project area.
- F. Surfaces which are to receive striping shall be thoroughly cleaned, free from loose materials and dry, and such areas shall be thus prepared by the Contractor to the satisfaction of the City Engineer.
- G. The completed stripes and markings shall have clean and well defined edges and their maximum deviations from the designated positions of the stripes shall not exceed one and one-half inch (1 1/2") in any 100 feet length of stripe, including gaps.
- H. Any damage to the newly placed stripe or marking due to the failure of any Contractor to protect his work, shall be repaired by him at no additional cost.

3.2 BITUMEN

- A. Bitumen adhesive shall be indirectly heated in an applicator with continuous agitation. The adhesive shall be applied at a temperature between 400°F and 425°F. Markers shall be placed immediately after application of the adhesive.

B. Replacement of markers using bitumen adhesive shall conform to the requirements for placing markers in Section 85-1.03 "Construction" of the Caltrans Standard Specifications, except as follows:

1. Markers shall not be placed when the pavement or air temperature is 50°F or less.
2. Blast cleaning of clean, new asphalt concrete surfaces will not be required.

PART 4 - PAYMENT

4.1 MEASUREMENT AND PAYMENT

A. Full compensation for conforming to the requirements of this section shall be considered as included in the prices paid for the various contract items of work involved and no additional compensation will be allowed.

++ END OF SECTION ++

SECTION 04100 – SIGNING

PART 1 - GENERAL

1.1 SPECIFICATIONS

- A. Traffic and access control shall conform to California Manual on Uniform Traffic Control Devices (CA MUTCD).
- B. Signs shall conform to Section 82, "Signs and Markers," of the Caltrans Standard Specifications and California Manual on Uniform Traffic Control Devices, as modified herein, and as directed by the City Engineer.
- C. City of Brentwood Standard Plan ST-12, ST-13, ST-30

1.2 SCOPE OF WORK

- A. The work to be done consists of sawcutting, demolition and removal of existing sign, resetting of existing ground sign on a new pole and related items of work of the form and dimensions as shown on the plans, as specified in the Standard Specifications and these technical specifications, and as directed by the Engineer.

PART 2 - MATERIALS

2.1 CERTIFICATE OF COMPLIANCE

- A. Certificates of compliance shall be furnished for all signing. Certificate of compliance shall certify that the signing conforms to the prequalified testing and approval of the Department of Transportation, Division of Traffic Operations and was manufactured in accordance with the approved quality control program.

PART 3 - EXECUTION

3.1 ROADSIDE SIGNS

- A. Roadside signs shall be installed at locations shown on the plans per City of Brentwood Standard Plan ST-12, ST-13, ST-30 and per Caltrans Standard Specification Section 82.
- B. Installation of roadside signs on street light poles shall not damage or scratch the paint of the street light. Any damage to the street light pole shall be repaired by the Contractor at his own cost.
- C. Any damage to the relocated sign shall be repaired by the Contractor to the satisfaction of the Engineer and all costs of such repair shall be the sole responsibility of the Contractor.
- D. All newly installed roadside signs shall be continuously covered from view, as directed by the Engineer, until they are required to control traffic. The Engineer shall direct the Contractor when the new signs are to be uncovered.
- E. Existing roadside signs, at locations shown on the plans to be salvaged, shall be removed and salvaged. Salvaged signs shall be delivered to the City of Brentwood, 2201 Elkins Way, Brentwood, CA 94513.

- F. Salvaged roadside signs shall not be removed until replacement signs have been installed or until the existing signs are no longer required for the direction of public traffic, unless otherwise directed by the Engineer.
- G. Each multi-post or single post sign with one or more sign panels mounted on the post shall be considered a single unit for measurement and payment purposes.

PART 4 - PAYMENT

4.1 MEASUREMENT AND PAYMENT

- A. **Remove and Replace Sign Post and Reset Sign** shall be measured by **each** and paid for in accordance with Article 8 of the General Conditions and Section 01015 – SUMMARY OF BID ITEMS.

++ END OF SECTION ++

APPENDICES

The Appendices, which includes all of the items listed below, can be found on the City's website at the following link: <https://www.brentwoodca.gov/government/projects-bids-rfps>.

Appendix A Plans

Appendix B Standard Plans

- ST-7a Residential Driveway with Separated Sidewalk
- ST-7b Residential Driveway with Adjacent Sidewalk
- ST-13 Roadside Breakaway Sign Post
- ST-17 Concrete Walkway Detail
- ST-21a Accessible Curb Ramp Type "A" and "B"
- ST-21b Accessible Curb Ramp Type "C" and "D"
- ST-21c Accessible Curb Ramp Details
- ST-21d Accessible Curb Ramp Notes-1
- ST-21e Accessible Curb Ramp Notes-2
- ST-23 Sidewalk, Curb and Gutter

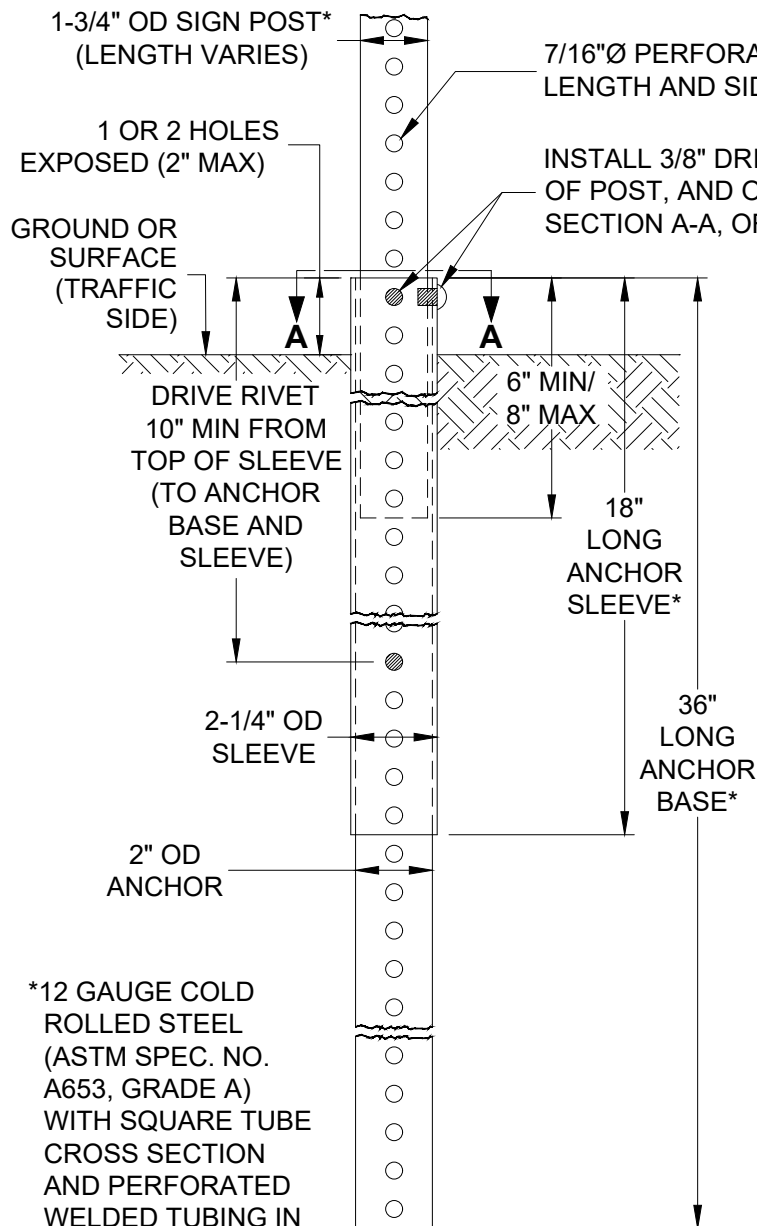

7/16"Ø PERFORATIONS, BACK-TO-BACK, ALONG FULL LENGTH AND SIDES OF ALL MEMBERS* AT 1" OC (TYP)

INSTALL 3/8" DRIVE RIVETS (TYP): ONE ON BACKSIDE OF POST, AND ONE ON SIDE OF POST AS SHOWN ON SECTION A-A, OR AS DIRECTED BY THE CITY ENGINEER

NOTES:

1. FOR INSTALLATION ON UNDISTURBED EARTH OR CONCRETE SIDEWALK. DISTURBED EARTH REQUIRES A COMPACTION OF 95% AROUND ITS SURROUNDING AREAS.
2. TELESCOPE THE ANCHOR SLEEVE OVER THE ANCHOR BASE UNTIL BOTH TUBES ARE FLUSH AT THE TOP AND THE PERFORATIONS ALIGN.
3. USE DRIVING CAP TO PROTECT THE END OF ALL MEMBERS WHEN THE ANCHOR ASSEMBLY IS BEING DRIVEN INTO THE GROUND.
4. STABILIZATION ANCHOR SLEEVES SHALL BE USED IN ALL AREAS WITH SOFT, LOOSE OR UNSTABLE SOILS.
5. SEE ST-12 FOR STREET SIGN DETAIL.
6. WRAP POST IN SLEEVE IF PLACED IN CONCRETE.

*12 GAUGE COLD ROLLED STEEL (ASTM SPEC. NO. A653, GRADE A) WITH SQUARE TUBE CROSS SECTION AND PERFORATED WELDED TUBING IN GALVANIZED FINISH CONFORMING TO ASTM SPEC. NO. A653 COATING DESIGNATION G90.

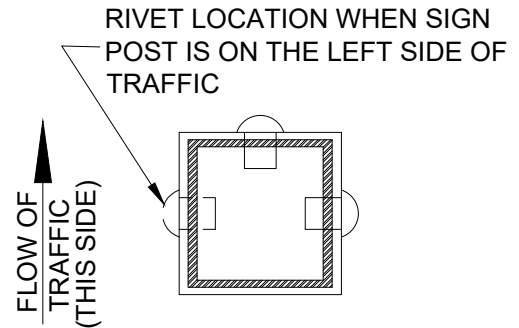

RIVET LOCATION SECTION A-A

(Not To Scale)



ENGINEERING DEPARTMENT



ROADSIDE BREAKAWAY SIGN POST

Allen S. Baquilar
ALLEN S. BAQUILAR

CITY ENGINEER

DATE: FEBRUARY 1, 2019

REVISED:

SHEET No.

ST-13

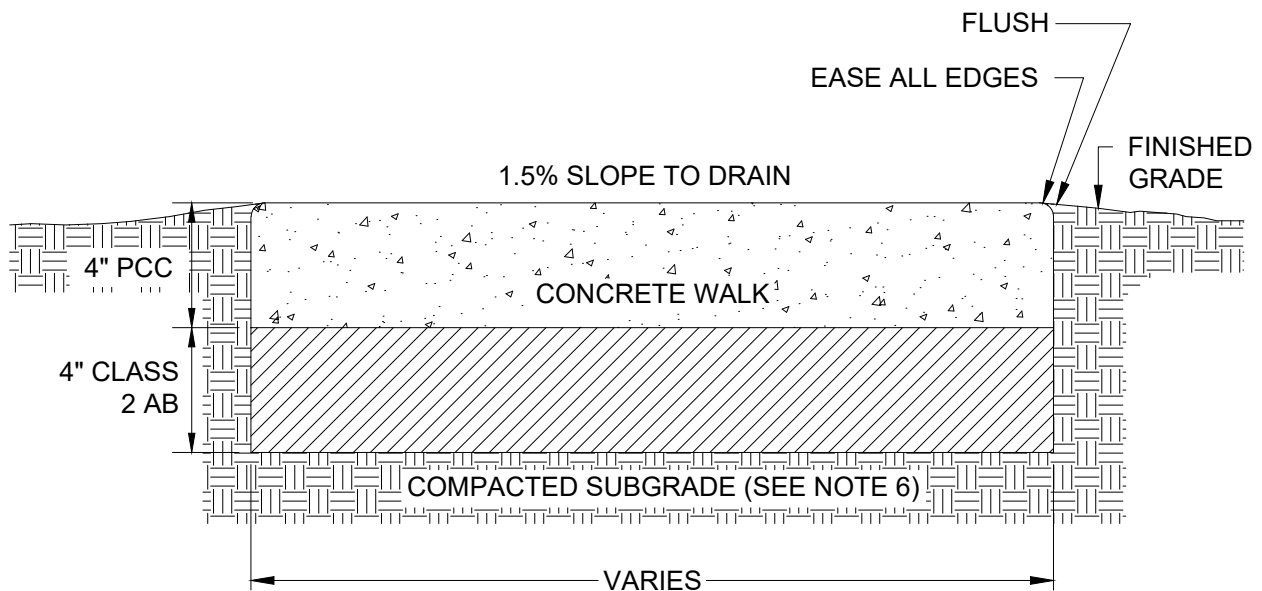

NOTES:

1. CONSTRUCT WEAKENED PLANE JOINTS 1" DEEP AT 5' ON CENTER.
2. CONSTRUCT EXPANSION JOINTS AT 20' INTERVALS AND WHERE NEW CONCRETE JOINS EXISTING OR OTHER SURFACING.
3. ALL CONCRETE SHALL HAVE A MINIMUM COMPRESSIVE STRENGTH OF 2,500 P.S.I. WITH 1½ LBS. FIBRILLATED POLYPROPELENE FIBERS PER CUBIC YARD.
4. BROOM FINISH WALK AT RIGHT ANGLES TO CURB.
5. ALL CONCRETE SHALL HAVE A MINIMUM OF 4" CLASS 2 A.B. @ 95% RELATIVE COMPACTION ON SUBGRADE @ 95% RELATIVE COMPACTION. THE USE OF RECYCLED A.B. SHALL NOT BE ALLOWED.

(Not To Scale)



**ENGINEERING
DEPARTMENT**



CONCRETE WALKWAY DETAIL

Allen Baquilar
ALLEN S. BAQUILAR

CITY ENGINEER

DATE: FEBRUARY 1, 2019

REVISED:

SHEET No.

ST-17

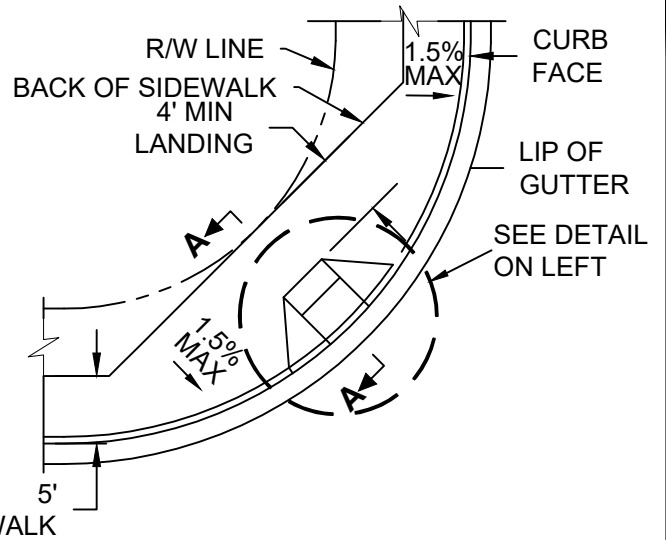
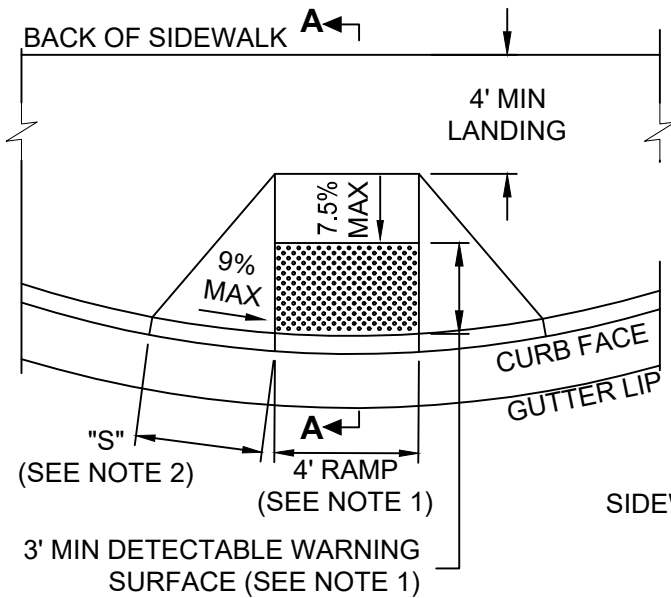

TYPE "A"

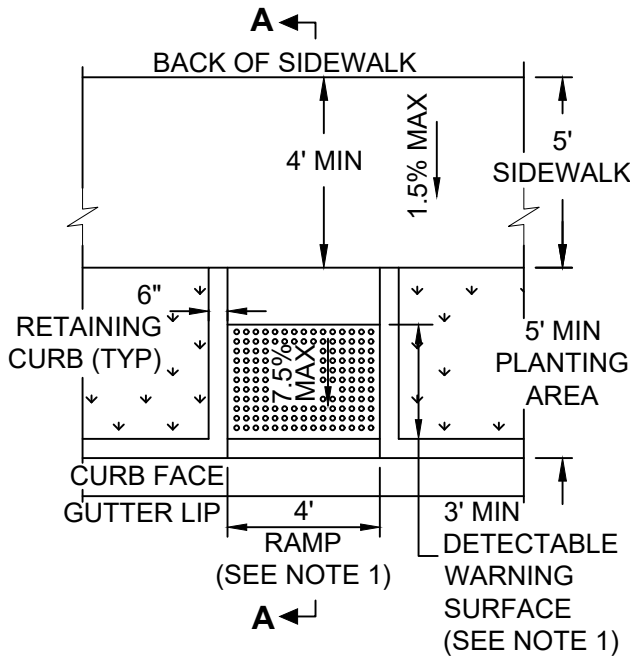

TYPE "B"

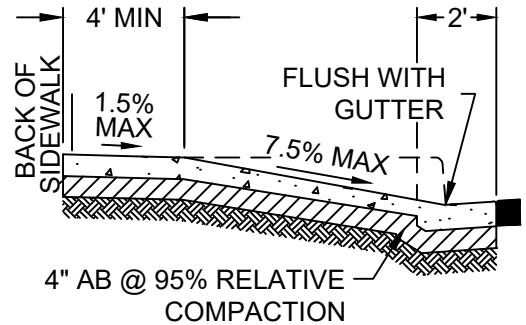

SECTION A-A

NOTES:

1. CURB RAMPS SHALL HAVE A DETECTABLE WARNING SURFACE. SEE ACCESSIBLE CURB RAMP DETAILS ON ST-21c AND NOTE 11 ON ST-21d.
2. "S"=SLOPE DISTANCE (SEE TABLE ON ST-21d).
3. SEE ST-21d AND ST-21e FOR ADDITIONAL ACCESSIBLE CURB NOTES.
4. FOR RIGHT-OF-WAY ONLY, REFER TO CALIFORNIA BUILDING CODE FOR REQUIREMENTS ON PRIVATE PROPERTY.

(Not To Scale)



**ENGINEERING
DEPARTMENT**



**ACCESSIBLE CURB RAMP
TYPE "A" AND "B"**

Allen Baquillar
ALLEN S. BAQUILLAR

CITY ENGINEER

DATE: MARCH 10, 2023

REVISED:

SHEET No.

ST-21a

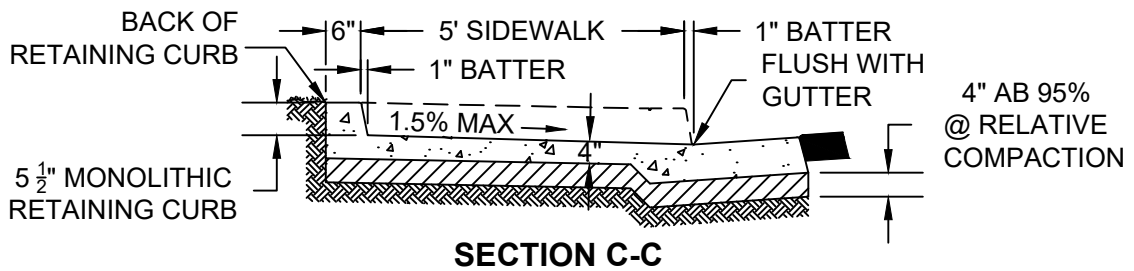
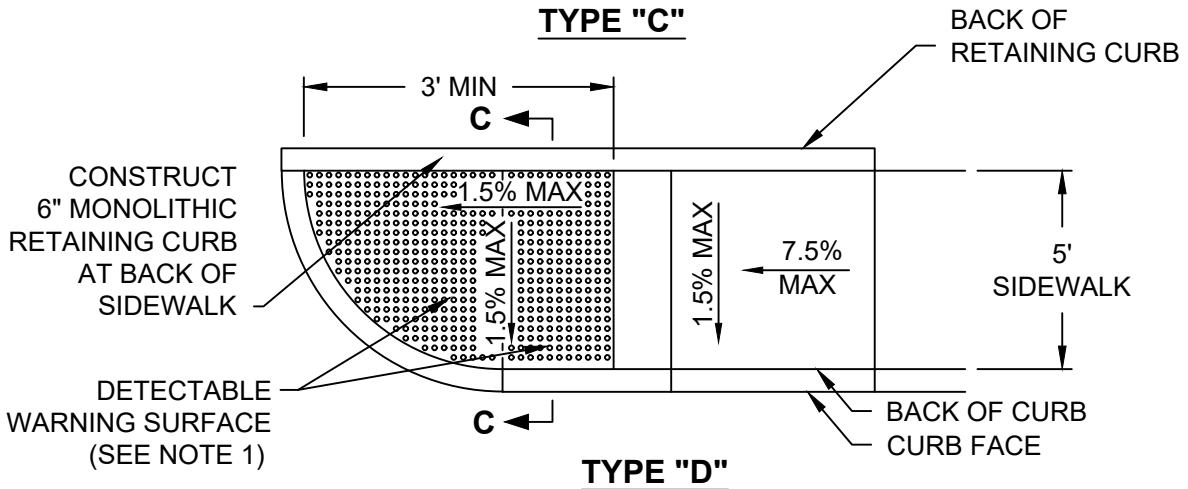
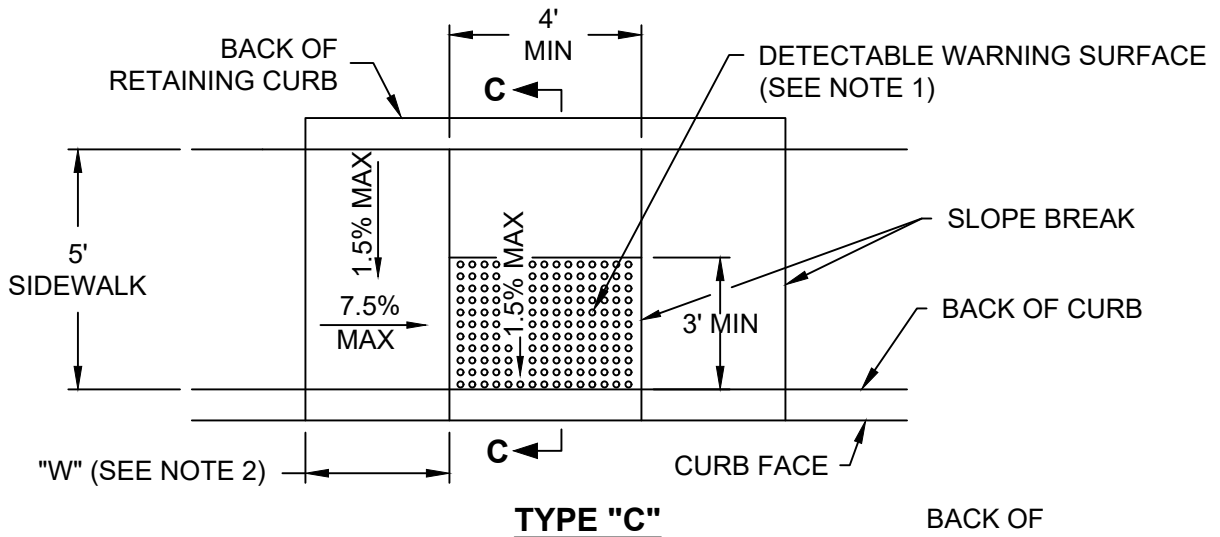

NOTES:

1. CURB RAMPS SHALL HAVE A DETECTABLE WARNING SURFACE. SEE NOTE 11 ON ST-21d FOR DETECTABLE WARNING SURFACES AND TRUNCATED DOME GENERAL INFORMATION.
2. "W" = CURB HEIGHT MAX SLOPE DIMENSION (SEE TABLE ON ST-21d).
3. SEE ST-21d & ST-21e FOR ADDITIONAL ACCESSIBLE CURB RAMP NOTES.
4. FOR RIGHT-OF-WAY ONLY, REFER TO CALIFORNIA BUILDING CODE FOR REQUIREMENTS ON PRIVATE PROPERTY.

(Not To Scale)



**ENGINEERING
DEPARTMENT**



**ACCESSIBLE CURB RAMP
TYPE "C" AND "D"**

Allen Baquillar
ALLEN S. BAQUILLAR

CITY ENGINEER

DATE: MARCH 10, 2023

REVISED:

SHEET No.

ST-21b

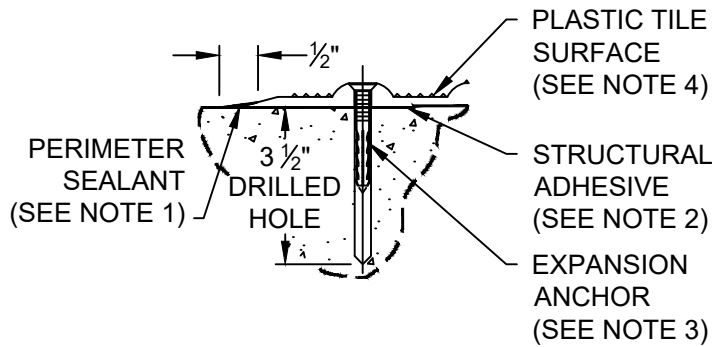

SURFACE APPLIED TILE INSTALLATION

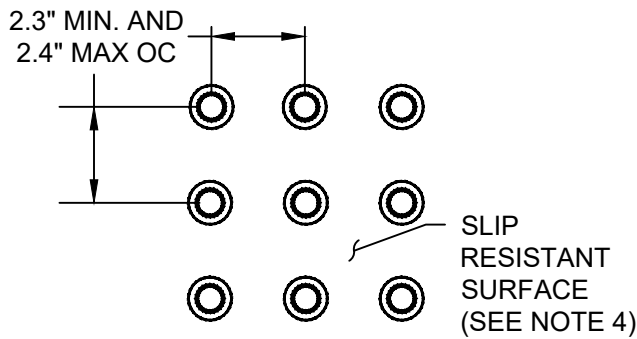

RAISED TRUNCATED DOME PATTERN

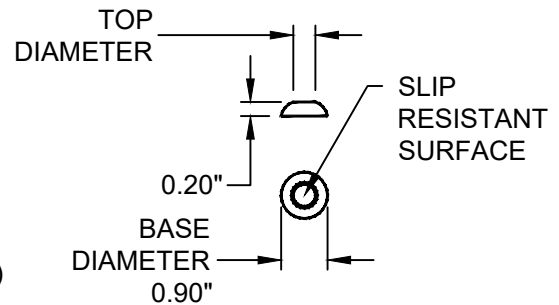

RAISED TRUNCATED DOME

NOTES:

1. APPLY SEALANT AT PERIMETER OF PLASTIC TILE AFTER FASTENING. TOOL SMOOTH TO BLEND TILE EDGE WITH ADJACENT SURFACE.
2. APPLY STRUCTURAL ADHESIVE AT FULL PERIMETER AND THROUGH CENTER OF PLASTIC TILE EACH WAY.
3. 1/4" x 1 1/2" LG COLOR MATCHED EXPANSION ANCHOR PART NO. ADA-S-FAST 12" O.C.
4. SLIP RESISTANT PLASTIC TILE SURFACE. PLASTIC TILES WITH A MIN. OF 40 POINTS PER SQUARE INCH.
5. SEE ST-21d & ST-21e FOR ADDITIONAL ACCESSIBLE CURB RAMP NOTES.
6. FOR RIGHT-OF-WAY ONLY, REFER TO CALIFORNIA BUILDING CODE FOR REQUIREMENTS ON PRIVATE PROPERTY.

(Not To Scale)



**ENGINEERING
DEPARTMENT**



**ACCESSIBLE CURB RAMP
DETAILS**

Allen Baquillar
ALLEN S. BAQUILLAR

CITY ENGINEER

DATE: MARCH 10, 2023

REVISED:

SHEET No.

ST-21c

CURB HEIGHT SLOPE DIMENSIONS TABLE

CURB HEIGHT	DISTANCE "S" (MIN)	SLOPE "W" (MIN)
4"	3.704'	4.44'
5"	4.63'	5.56'
6"	5.56'	6.67'
7"	6.48'	7.78'
8"	7.41'	8.89'

NOTES:

1. ACCESSIBLE CURB RAMPS SHALL BE CONSTRUCTED AT MIDPOINT OF CURB RETURNS.
2. CONCRETE SHALL HAVE A MINIMUM COMPRESSION STRENGTH OF 2,500 P.S.I. WITH 1-1/2 LBS. FIBRILLATED POLYPROPYLENE FIBERS PER CUBIC YARD.
3. CONCRETE SHALL HAVE A MINIMUM OF 4" CLASS 2 A.B. @ 95% RELATIVE COMPACTION ON SUBGRADE @ 95% RELATIVE COMPACTION. THE USE OF RECYCLED A.B. IS NOT ALLOWED UNLESS AUTHORIZED BY THE CITY ENGINEER.
4. RAMPS SHALL HAVE A HEAVY BROOM FINISH TRANSVERSE TO THE SLOPE OF THE RAMP AND DEEP SCORE LINES AT LEADING EDGE OF TACTILE STRIPS.
5. CROSSWALKS SHALL BE CENTERED ON THE LANDING OF THE ACCESSIBLE CURB RAMP.
6. CURB RAMP SIDE SLOPE VARIES UNIFORMLY TO A MAXIMUM OF 10% AT CURB TO CONFORM WITH LONGITUDINAL SIDEWALK SLOPE ADJACENT TO TOP OF RAMP, EXCEPT IN TYPE 'C' OR 'D'
7. UTILITY PULL BOXES, MANHOLES, VAULTS, AND ALL OTHER UTILITY FACILITIES WITHIN THE BOUNDARIES OF THE CURB RAMP WILL BE RELOCATED BY OTHERS PRIOR TO, OR IN CONJUNCTION WITH, CURB RAMP CONSTRUCTION.
8. DOWEL CURB RAMPS AT ALL COLD JOINTS IN EXISTING CONCRETE WITH #4 REBAR 12" LONG AT 36" INTERVALS. DRIVE TIGHT FIT OR EPOXY. EXPANSION JOINTS AND/OR WEAKENED PLANE JOINTS SHALL SEPARATE CURB RAMPS IN NEW CONCRETE CONSTRUCTION.
9. ALL SLOPES RELATIVE TO EXISTING STREET GRADES.
10. GENERAL NOTES ON TRUNCATED DOMES:
 - A. ACCESSIBLE CURB RAMPS SHALL HAVE A PREFABRICATED DETECTABLE WARNING SURFACE INSTALLED ON RAMP SURFACE CONSISTING OF TILE(S) WITH RAISED TRUNCATED DOMES CONFORMING TO THE DETAILS ON THIS STANDARD PLAN AND IN CONFORMANCE WITH THE REQUIREMENTS ESTABLISHED BY THE DEPARTMENT OF GENERAL SERVICES, DIVISION OF STATE ARCHITECT; AND THE AMERICAN WITH DISABILITIES ACT (TITLE 49 CFR TRANSPORTATION, PART 37.9 STANDARDS FOR ACCESSIBLE TRANSPORTATION FACILITIES, APPENDIX A, SECTION 4.29.2 DETECTABLE WARNINGS ON WALKING SURFACES) AND SHALL BE CAST IN PLACE IN CONFORMANCE WITH THE MANUFACTURER'S CAST IN PLACE RECOMMENDATIONS.
 - B. DETECTABLE WARNING SURFACE SHALL EXTEND THE FULL WIDTH AND 3' DEPTH OF THE RAMP. THE EDGE OF THE DETECTABLE WARNING SURFACE NEAREST THE STREET SHALL BE BETWEEN 6" AND 8" FROM THE GUTTER FLOWLINE. WHEN A DETECTABLE SURFACE EDGE AND/OR DOMES IS CUT AND THE RESULTING EDGE IS NOT FLUSH WITH THE SURFACE OF THE RAMP, THE EDGE SHALL BE BEVELED OR CONFORMED WITH PERIMETER SEALANT AT 1:2 MAX. SLOPE IN ACCORDANCE WITH THE MANUFACTURER'S REQUIREMENTS.

(Not To Scale)



**ENGINEERING
DEPARTMENT**



**ACCESSIBLE CURB RAMP
NOTES-1**

Allen Baquilar
ALLEN S. BAQUILAR

CITY ENGINEER

DATE: MARCH 10, 2023

REVISED:

SHEET No.

ST-21d

NOTES:

- 11. MANUFACTURER(S) WARRANTY ON TRUNCATED DOMES:
MANUFACTURER(S) SHALL PROVIDE A WRITTEN 5-YEAR WARRANTY FOR PREFABRICATED DETECTABLE WARNING SURFACES, GUARANTEEING REPLACEMENT WHEN THERE IS DEFECT IN THE DOME SHAPE, COLOR FASTNESS, SOUND-ON-CANE ACOUSTIC QUALITY, RESILIENCE, OR ATTACHMENT. WARRANTY PERIOD SHALL BEGIN UPON ACCEPTANCE OF WORK.
- 12. TRUNCATED DOMES SPECIFICATIONS:
 - A. PLASTIC TILES SHALL BE "ARMOR TILE" AS MANUFACTURED BY ENGINEERED PLASTICS INC., OR APPROVED EQUAL, TEL: (800) 682-2525. TILES SHALL BE A SINGLE TILE, 36" x 48" NOMINAL, MANUFACTURED OF AN EPOXY POLYMER COMPOSITE WITH AN ULTRAVIOLET STABILIZED, COLORFAST COATING EMPLOYING ALUMINUM OXIDE PARTICLES IN THE TRUNCATED CONES.
 - B. COLOR SHALL BE YELLOW COLOR NO. 33538 OF AMS-STD-595.
 - C. THE TILE SHALL INCORPORATE AN IN-LINE PATTERN OF TRUNCATED DOMES; .20" IN HEIGHT, .90" DIAMETER AT THE BASE, AND .40" DIAMETER AT THE TOP OF DOME, SPACED 2.3" MIN. AND 2.4" MAX. ON CENTER AS MEASURED VERTICALLY AND HORIZONTALLY; ROWS SHALL BE ORIENTED PARALLEL WITH RAMP DIRECTION; DOMES SHALL BE ALIGNED THROUGHOUT ENTIRE DETECTABLE SURFACE AREA.
 - D. THE FIELD AREA SHALL CONSIST OF A NON-SLIP SURFACE WITH A MINIMUM OF 40 RAISED POINTS .045" HIGH, PER SQUARE INCH.
 - E. THE TILE SHALL BE MANUFACTURED WITH EMBEDMENT FLANGES, 3" CENTER TO CENTER, 1" MIN. DEPTH WITH $\frac{5}{16}$ " DIAMETER HOLES, 3 HOLES MINIMUM PER FLANGE. WHERE TILES ARE CUT, SEALANT SHALL BE WORKED UNDER THE TILE ALONG PERIMETER WHEREVER THE EMBEDMENT FLANGE IS REMOVED.
- 13. SURFACE APPLICATION ON TRUNCATED DOMES:
 - A. UPON APPROVAL FROM THE CITY ENGINEER, RETROFIT AND UNIQUE CIRCUMSTANCES MAY APPLY TO SURFACE APPLICATION ON TRUNCATED DOMES.
 - B. SURFACE APPLIED DETECTABLE TILES SHALL BE "ARMOR TILE" MANUFACTURED WITHOUT EMBEDMENT FLANGES AND THE EDGES SHALL BE BEVELED, SLOPED AT 1:2 MAXIMUM WHEN THE DETECTABLE SURFACE EDGE AND/OR DOME IS CUT AND THE RESULTING EDGE IS NOT FLUSH WITH THE SURFACE OF THE RAMP, THE EDGE SHALL BE BEVELED OR CONFORMED WITH PERIMETER SEALANT AT 1:2 MAXIMUM SLOPE IN ACCORDANCE WITH THE MANUFACTURER'S REQUIREMENTS.
 - C. ADHESIVE: URETHANE ELECTROMETRIC ADHESIVE BY SKA CORP., UNIROYAL, MAPEI, BOSTIK, OR APPROVED EQUAL.
 - D. FASTENERS: COLOR MATCHED, CORROSION RESISTANT, FLAT HEAD DRIVE ANCHOR: $\frac{1}{4}$ " DIAMETER x 1- $\frac{1}{2}$ " LONG, 12" CENTER TO CENTER BOTH DIRECTIONS MIN. ARMOR-DRIVE BY ENGINEERED PLASTICS OR APPROVED EQUAL.
 - E. PERIMETER SEALANT: EPOXY TWO COMPONENT SEALANT BY POWERS, SIMPSON, HILTI OR APPROVED EQUAL. ALUMINUM GRAY COLOR.

(Not To Scale)



**ENGINEERING
DEPARTMENT**



**ACCESSIBLE CURB RAMP
NOTES-2**

Allen Baquilar
ALLEN S. BAQUILAR

CITY ENGINEER

DATE: MARCH 10, 2023

REVISED:

SHEET No.

ST-21e

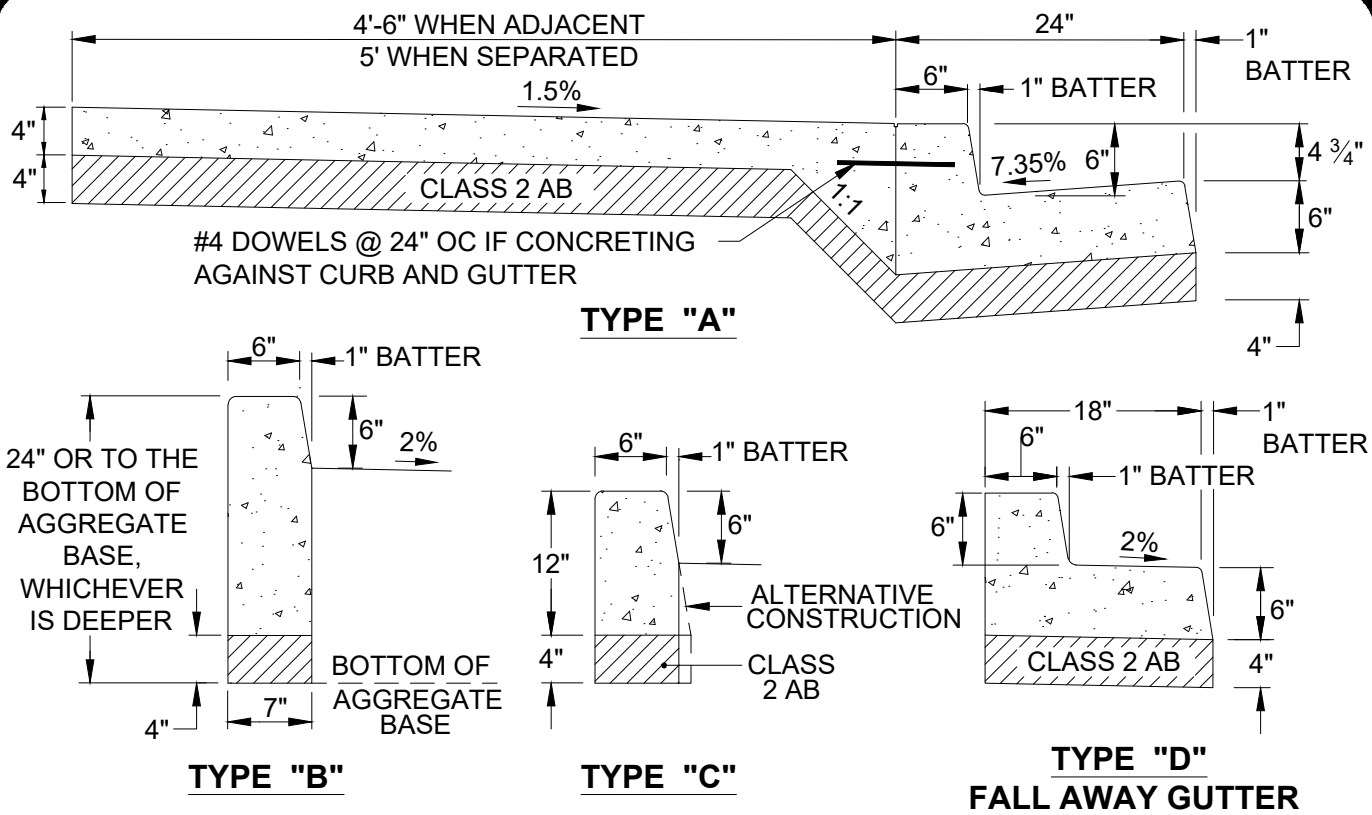

NOTES:

1. ALL CONCRETE SHALL HAVE A MINIMUM STRENGTH OF 2,500 P.S.I., WITH 1½ LBS FIBRILLATED POLYPROPYLENE FIBERS PER CUBIC YARD.
2. A PERFORATED DRAIN PIPE SHALL BE INSTALLED ON TYPES "A", "C" AND "D" PER CITY STANDARD ST-24.
3. ALL CURB TYPES AND SIDEWALK SHALL HAVE A 1" MIN. DEEP SCORE MARK EVERY 10'. IN ADDITION, SIDEWALK SHALL HAVE A ¼" x ¼" SHALLOW SCORE MARK 5' O.C. FROM THE DEEP SCORE MARK.
4. BROOM FINISH WALK AT RIGHT ANGLES TO CURB; CURB AND GUTTER PARALLEL TO STREET.
5. INSCRIBE A 3" HIGH "W" OR "S" ON TOP OF THE CURB DIRECTLY ABOVE THE WATER OR SANITARY SEWER SERVICE.
6. ALL CONCRETE SHALL HAVE A MINIMUM OF 4" CLASS 2 A.B. @ 95% RELATIVE COMPACTION ON SUBGRADE @ 95% RELATIVE COMPACTION. THE USE OF RECYCLED A.B. SHALL NOT BE ALLOWED.
7. ALL CORNERS SHALL BE FINISHED WITH A ½" RADIUS.

(Not To Scale)



**ENGINEERING
DEPARTMENT**



SIDEWALK, CURB AND GUTTER

Allen Baquilar
ALLEN S. BAQUILAR CITY ENGINEER

DATE: FEBRUARY 1, 2019
REVISED:

SHEET No.
ST-23